

ISSN 0036-679X (print)
0972-5061 (online)

School Science

A QUARTERLY JOURNAL OF **SCIENCE EDUCATION**

Vol. 52 No. 1 March 2014



Dr E.K. Janaki Ammal was a founder member of the Indian Academy of Sciences and an emeritus fellow of the Indian National Science Academy and conferred with Padma Sri by the Government of India.

Editorial Advisory Committee

L.S. Kothari	Professor (Retired) 71, Vaishali Enclave Pitampura, Delhi 110 034
Arvind Kumar	Director (Former) Homi Bhabha Centre of Science Education TIFR, V.N. Purav Marg Mankhurd, Mumbai 400 088
Ashok Srivastava	Head Publication Division NCERT, New Delhi 110 016
Hukum Singh	Professor and Head DESM, NCERT New Delhi 110 016

Editorial Group (Academic)

A. K. Wazalwar	Chief Editor
Sunita Farkya	Executive Editor
R .P. Maurya	Member
Anjni Koul	Member
Alka Mehrotra	Member
R. R. Koireng	Member

Publication Team*

Dinesh Kumar	Head, Publication Division
Shveta Uppal	Chief Editor
Gautam Ganguly	Chief Business Manager
Arun Chitkara	Chief Production Officer (Incharge)
Prakash Veer Singh	Production Assistant

This issue is printed in February 2016
* The Publication Team is as per 2016

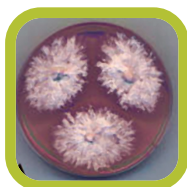

Contents

- 3 Editorial
- 4 Barbie Doll and Janaki Ammal: Careers of Women in Science
Varada M. Nikalje
- 10 Uniform Circular Motion
P.C. Agarwal
- 17 Effect of Concept Mapping Strategy on Achievement in Organic Chemistry of Class XII Science Students
Kanak sharma
- 35 Problem Based Learning in Basic Physics - IV
A.K. Mody and H.C. Pradhan
- 44 Rubrics to Refine Teaching Skills in Mathematics at the Secondary Stage
P.K. Chaurasia
- 66 'Effectiveness of Continuous and Comprehensive Evaluation (CCE) on the Development of Higher Mental Abilities in Science Students'
Nusrat Rizvi
- 72 Science News
- 96 Web Watch

CHILDREN'S BILL OF RIGHTS

A child is every person under the age of 18 years. Parents have the primary responsibility for the upbringing and development of the child. The State shall respect and ensure the rights of the child.

Dignity and Expression

- I have the right to know about my Rights. *(Article 42)*
- I have rights being a child and no matter who I am where I live, what my parents do, what language I speak, what religion I follow, whether I am a boy or a girl, what culture I belong to, whether I am disabled, whether I am rich or poor. I should not be treated unfairly on any basis. Everyone has the responsibility to know this. *(Article 2)*
- I have the Right to express my views freely which should be taken seriously, and everyone has the Responsibility to listen to others. *(Article 12,13)*
- I have the Right to make mistakes, and everyone has the Responsibility to accept we can learn from our mistakes. *(Article 28)*
- I have the Right to be included whatever my abilities, and everyone has the Responsibility to respect others for their differences. *(Article 23)*

Development

- I have the Right to a good education, and everyone has the Responsibility to encourage all children to go to school. *(Article 23, 28, 29)*
- I have the Right to good health care, and everyone has the Responsibility to help others get basic health care and safe water. *(Article 24)*
- I have the Right to be well fed, and everyone has the Responsibility to prevent people from starving. *(Article 24)*
- I have the Right to a clean environment, and everyone has the Responsibility not to pollute it. *(Article 29)*
- I have the Right to play and rest. *(Article 31)*

Care and Protection

- I have the Right to be loved and protected from harm and abuse, and everyone has the Responsibility to love and care for others. *(Article 19)*
- I have the Right to a family and a safe and comfortable home, and everyone has the Responsibility to make sure all children have a family and home. *(Article 9,27)*
- I have the Right to be proud of my heritage and beliefs, and everyone has the Responsibility to respect the culture and belief of others. *(Article 29,30)*
- I have the Right to live without violence (verbal, physical, emotional), and everyone has the Responsibility not to be violent to others. *(Article 28,37)*
- I have the Right to be protected from economic exploitation and sexual exploitation, and everyone has the Responsibility to ensure that no child is forced to work and is given a free and secure environment. *(Article 32,34)*
- I have the Right to protection from any kind of exploitation and everyone has the Responsibility to ensure that I am not being subjected to be taken advantage in any manner. *(Article 36)*

IN ALL ACTION CONCERNING CHILDREN, THE BEST INTERESTS
OF THE CHILD SHALL BE A PRIMARY CONSIDERATION

All these rights and responsibilities are enshrined in the United Nations Convention on the Rights of the Child, 1989. It contains all the rights which children have all over the world. The Government of India signed this document in 1992.

Source: National Commission for Protection of Child Rights (NCPCR), Government of India

EDITORIAL

The March 2014 issue of *School Science* contains a series of articles and research papers written and contributed by researchers and academicians from varied fields of Science. The first article "Barbie Doll and Janaki Ammal: Careers of Women in Science" is a critique on the societal notion that women are poor in studies or achieve less in the field of science. The article goes against the objectification of women as Barbie dolls. The author in the article talks about Janaki Ammal, one of the first women scientists who has broken the stereotype of girls and women as dolls and further claiming that dolls can also have other ambitions rather than merely putting on make-up and wearing fancy clothes.

The next article "Uniform Circular Motion" emphasises the concept of circular motion about the misconception among learners in related concepts. The author has tried to clear the doubts to ensure better understanding in the related concepts. The Journal also includes the article, "Effect of Concept Mapping Strategy on Achievement in Organic Chemistry of Class XII Science Students." In this, the author shows how concept mapping strategy will help students to improve their knowledge in Organic Chemistry and therefore, proving more effective than normal lecture method.

The issue also publishes the article "Problem Based Learning in Basic Physics – IV" which is a sequel to Part II and Part III, published in December-2011 and March-2012 issues. The authors bring forth problem-based learning in Physics pertaining to the area of heat, thermodynamics and optics.

The article, "Rubrics to Refine Teaching Skills in Mathematics at the Secondary Stage" highlights the significance of rubric is not only improving but also finding the learning difficulties of a learner. The author addresses the problems and solutions in teaching and learning Mathematics in this article. In the last article "Effectiveness of Continuous and Comprehensive Evaluation (CCE) on the Development of Higher Mental Abilities in Science Students", the author wants to see, as the title of the paper itself suggests, the effectiveness of CCE on the development of higher mental abilities i.e. application, analysis, synthesis and evaluation in science students.

Like the other issues, this issue also includes, the Science News and Web Watch for the readers.

We welcome comments and suggestions to enhance the quality of the Journal. We also wish our readers a very happy and joyous reading with the hope this issue will further the knowledge of science.

BARBIE DOLL AND JANAKI AMMAL: CAREERS OF WOMEN IN SCIENCE

Varada M. Nikalje

Assistant Professor, DEL

March eight is celebrated as Women's day throughout the world. Numerous schemes for the betterment of women are launched, and the contribution of women to society is lauded. In March 2013, the National Council of Educational Research and Training (NCERT) New Delhi, marked the occasion by re-naming one of the buildings of NCERT. Earlier referred to ubiquitously as the Science Block, the building was henceforth to be known as 'Janaki Ammal Block'. A small, almost innocuous step, but one that had a ripple effect. 'Janaki Ammal who?' was the reaction of most colleagues and friends. We made a beeline for the Internet, firm in the belief "Don't think, just Google!". We saw the image of a wrinkled, intelligent face, a replica of which would be later embossed on the outer wall of the building. We learnt that Ammal was born in 1897, that she had studied abroad, that she later returned to India to become a Professor of Botany, and that Pandit Nehru, the then Prime Minister of India, invited her to accept an assignment as Special Officer to re-organise the Botanical Survey of India. She devoted her energy and enthusiasm to science, which, to her, was both a profession and a passion. As the poet Robert Frost puts it, if one works at what one loves, life becomes a fulfilment:

"My object in living is to unite
My avocation and my vocation
As my two eyes make one in sight."

Janaki Ammal's choice of vocation was unusual, all the more striking in the pre-independence era. Her work covered specialised aspects of genetics, evolution, phytogeography and ethnography, at a time when education for girls was still a big no-no.



The 20th century has witnessed changes in access to education: from being confined to the elite, it is now available to the masses; earlier, boys were priviledged, now girls too are sent to school; formerly, education was considered essential, now it is a fundamental right. Yet the glass ceiling remains. In other words, women opt for higher education and a variety of vocations, but as they move upwards, their numbers dwindle. The field of science, as with most fields, is dominated by men. While women have contributed to scientific

discoveries and advancements in various fields such as medicine, mathematics and chemistry, the problem lies in the lack of recognition and popularisation of their achievements.

In India, the issue of gender in the field of science is to be viewed against the backdrop of feudal authoritarianism and patriarchal values. A stereotype regarding girls persists in India, "which encourages the belief that they are not interested in mathematics and science. This perception is grounded in the notion that inferiority and inequality are inherent in gender." (NCF-2005, 23) Since the time when girls first entered school in large numbers, their performance vis-a-vis boys has been the subject of conscious or unconscious evaluation. Although today most liberal-minded persons would deny that there are differences in intelligence between girls and boys, some stereotypes do persist. Dr Ramdadas, in her monthly column on science education in *The Economic Times* says that "A popular idea is that if girls do well in exams, it is due to their hard work and 'cramming' which is, supposedly, a natural result of their docile and conformist nature. If boys do well, their success is more likely to be attributed to natural intelligence." (Ramadas, 15)

Cognitive decisions are influenced by cultural attitudes to learning. Undoubtedly, our society conveys different messages, subtly and not so subtly, to boys and girls about cultural norms. Toys for girls almost automatically translate as dolls, and little girls are encouraged to "play house", exhibiting their nurturing side in preparation for a lifetime of housewife, nurse and child caregiver. Even when girls are fortunate enough to get education, few follow the rigorous disciplines of pure mathematics and science.

Today, careers such as acting, modelling, reality shows, journalism and corporate sector seem more interesting and appealing to young girls who are dazzled by their glamour and lucrative rewards.

Most girls in urban middle-class and elite families have, at one time or the other, owned at least one Barbie. Barbie look-alike abound in lower economic status families. No one seems to mind the incongruous blonde hair and blue eyes.

One begins to wonder:

- (i) Does playing with Barbie dolls (and its look-alike) slowly create a negative self-image?
- (ii) Are the manufacturers of Barbie aware of the implications of young girls viewing Barbie as a role model?
- (iii) Have the manufacturers tried to break the 'girly' stereotype?

Barbie doll is projected as every girl's longing. The blonde haired doll, in pretty pink, with tiny accessories such as shoes and handbags and hairbands is certainly great fun to play with. The trouble arises when it leads to flawed thinking of oneself. The vital statistics of Barbie are unrealistic, and are unobtainable by humans. Research has shown that, if real women were shaped in the same proportions as the doll, they



would have an impossibly small waist, and there would be inadequate space for liver and intestines. The extremely slender neck would ensure that women would never be able to walk with heads held high! More disturbing are the results of a psychological study quoted in Wikipedia. The study selected 162 girls from 5-8 years, and divided them into three groups. The first group was exposed to images of a Barbie Doll; the second to Emme, a new full-figured doll; the third group served as baseline control and were not exposed to any doll. The group that was shown a Barbie doll, it was found, had less self-esteem about their bodies, and quickly developed a strong desire to be thin. Play is a vital part of socialisation of young children, in which they gradually internalise ideals and values. The findings of the study indicated that an early exposure to dolls that epitomise an unrealistically thin body may create a negative self-image in young girls, which could further contribute to an increased risk of disordered eating and an unhealthy preoccupation with body weight. In short, little girls ought to be happily playing, not thinking about size zero.

The latter half of the 20th century saw women stepping out of their homes, into various careers. They entered an ambiguous world: ambitious, guilt ridden, grateful for political equality, yet unsure about handling both home and career. But there was no looking back. In the 1970s, when role models for girls in male-dominated society were sorely lacking, advocates of gender equality began to lobby toy makers and book publishers to design products depicting career options for girls, because these materials shape the ideas and ambitions in childhood. In the 1980s, when the feminist movement was soaring, Barbie was a prime hate object for feminists,

because the doll seemed to symbolise conventional feminine beauty standards with a mind-set limited to home, accessories and material possessions only, with no other ambition. There was even a song on the theme:

I'm a Barbie girl, in the Barbie world
Life in plastic, it's fantastic!

You can brush my hair, undress me everywhere
Imagination, life is your creation

Make me walk, make me talk,
do whatever you please

I can act like a star,
I can beg on my knees

You can touch, you can play, if you say:
"I'm always yours"

You can touch, you can play, if you say:
"I'm always yours"

The girl pictured in the video as Barbie is all pink, pretty, fluffy and totally air-brained, symbolising the ultimate male projection of feminine qualities.

Over the next two decades, toy makers gradually began to absorb the changes in the role of women in society. Mattel, the toy company that produces Barbie, brought out the doll in 125 career avatars, with the statement "Barbie career choices are unlimited and so are yours". Thus, started the 'I Can Be' series of Barbie Dolls. Each doll was sold with sets of clothes and accessories suitable to the career being portrayed. The Lifeguard Barbie, for instance, includes an outfit with shoes, a lifeguard chair, a dolphin and a life preserver. The careers are varied. Barbie began as a teenage

fashion model (1959), the flight attendant (1961) and later astronaut (1965). Barbie Miss Astronaut was released in 1965, two years after Soviet Cosmonaut Valentina Tereshkova became the world's first woman to fly into space.



The doll had a silver spacesuit with brown mittens and boots, along with a white helmet and an American flag. Twenty years later, a new Astronaut Barbie was released, after an American woman Sally Ride went into space. This doll had a pink and silver mini-skirt with sparkles and tights. The next few years saw glowing moon rocks and NASA's emblem added to the package. These were aspirational yet relevant, serving as roles of the changing face of women. In fact, Barbie was an astronaut four years before Neil Amstrong!

In 1975, Barbie was portrayed as an athlete, then as a teacher (1985) and a doctor (1988).

Yet, there was still dissatisfaction about the stereotypical imagery of her accessories, and their implications. For instance, the packing says that Barbie is a 'baby doctor', (an unnecessary dumbing-down of paediatrician). Her accessories are a stethoscope, an otoscope (tool to examine ears) two cute babies and lollipops. She wears jeans with pink glitters, not professional medical attire. Would it imply that girls, even when they follow careers, should

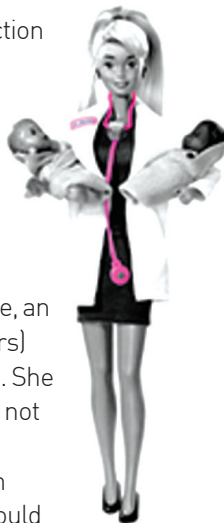

be beautiful in a picture-perfect way, and always be surrounded by cute pink things?

Just as these efforts seemed to boost careers for women in science, controversy would erupt. In 1992, Mattel brought out 'Teen-Talk Barbie', which had some utterances programmed into her. Each doll could utter four phrases, selected randomly out of 270 phrases by a computer. One such phrase was 'Math class is tough'. The American Association of University Women attacked the phrase stating that young girls may imbibe the potentially negative implications of the phrase. Mattel apologised in writing, and began offering a swap for anyone who brought in a doll that said the offensive phrase.

One far reaching effect of this controversy was that Mattel began to consult women established in their careers prior to launching a new avatar of Barbie. For instance, computer Engineer Barbie had accessories chosen with the help of the Society of Women Engineers and the National

Academy of Engineering, USA. The doll wears a neon-coloured T-shirt with a binary code pattern. She has pink framed glasses, and a laptop, also in pink and carries a Bluetooth headset.

This also marked an important shift in the company policy. Mattel now began to use polling as a strategy to decide on the next career for Barbie. The toy company asked people to vote online for her career, choosing among computer engineer, architect, environmentalist, news anchor and surgeon. Out of more than 6,00,000 votes cast, a surprisingly large number were for adults, including men. The computer engineer version got the highest number of votes. "All the girls who imagine their futures through Barbie will learn that engineers, like girls, are free to explore infinite possibilities, limited only by their imagination," says Nora Lin, President, Society of Women Engineers. "As a computer engineer, Barbie will show girls that women can turn their ideas into realities that have a direct and positive impact on people's everyday lives in this exciting and rewarding career." Further analysis of the results showed that there was a sharp bifurcation: adult voters gave Barbie her new computer scientist version, little girls wanted her to be an anchor woman/journalist. Wisely, Mattel released both versions.

However, sadly enough Environmentalist Barbie hit the dust. The word 'Environmentalist' reminded me of Janaki Ammal.

With so much awareness and exposure to the environment friendly causes such as planting trees, helping animals and saving whales, how is it that environmentalist was not a popular option whether for Barbie or for a career? Should numbers in an opinion poll matter so much to a

toy manufacturer? Should the approval of half a dozen family members and two dozen friends matter in a girl's career choice? In the group photograph taken at the Silver Jubilee of the Indian Science Academy, 1960, with Prime Minister Jawaharlal Nehru, it is noteworthy that Ammal was the only lady; numerically speaking, one. But one with a passion that led her to choose Botany, and latter specialised in cytology, in which she undertook chromosome studies of a wide range of garden plants. Ammal was an original thinker. She identified the confluence of Chinese and Malaysian elements in the flora of the northeast India that led to natural hybridisation between these and the native flora, contributing further to plant diversification. Today, the Janaki Ammal Herbarium at RRL, Jammu, houses 25,000 species taken from all over India.

Janaki Ammal was fortunate enough to have had liberal-minded parents. Their ideas regarding education and gender sensitivity were far ahead of their times. It was they who recognised the young Janaki's passion for plants and nurtured it into a career. The tragedy, however, is that there were thousands of women who, had they been educated and encouraged to take up careers, might have contributed to national development. As the poet Gray poignantly says, of wasted talent:

"Full many a gem of purest ray serene,

The deep unfathomed caves of ocean bear;

Full many a flower is born to blush unseen,

And waste its fragrance in the desert air."

I closed my eyes and pictured Janaki Ammal, in a sparsely furnished room, dressed in non-fussy cotton, seated at a table, lost in thought. There is a

pencil laid on notes carelessly bunched together, plant samples are on the sideboard. I pictured the door slowly opening. Barbie enters and stand beside her. Ammal glances at her. 'You are an iconic doll'. Ammal says 'Like it or not, you can send a powerful message to young girls'. But (and here she gives Barbie a disapproving look) 'Why doesn't your suit include GLOVES? And don't you have anything to collect samples with tools to explore with, or do research?'

Janaki Ammal is right. Enthusiasm is all very well, but one should also cultivate a working knowledge of the tools involved, as well as expertise in a chosen discipline. We need to ensure that girls have access to, and are aware of the entire spectrum of opportunities open to them. Anything that sends a positive message in this regard is welcome, including Barbie. And they will need to be, as a society grappling with global problems cannot afford to lose out on the brain power of women.

References

"**Barbie Girl**" is a song by the Danish -Norwegian dance group Aqua. It was released in May 1997. A footnote on the back of their *Aquarium* CD case precisely stated that "The song 'Barbie Girl' is a social comment and was not created or approved by the makers of the doll."

BROWNELL, K. D. AND M. A. NAPOLITANO. 1995. Distorting reality for children: Body size proportions of Barbie and Ken dolls. *International Journal of Eating Disorders*, 18(3), 295-298.

DITTMAR, H., E. HALLIWELL AND S. IVE. 2006. Does Barbie make girls want to be thin? The effect of experimental exposure to images of dolls on the body image of 5- to 8- year-old girls. *Developmental Psychology*. 42(2), 283-292.

JAYASHREE, RAMADAS. 'Imagined Stereotypes' in the monthly column "First Principles". *The Economic Times*. Vol. 33. No. 79. 22 May 1993. Web: www.hbcse.tifr.res.in/data/pdf/first-principles.pdf.

NATIONAL CURRICULUM FRAMEWORK-2005. National Council of Educational Research and Training, New Delhi.

PEARLMAN, ROBERT Z. 'Mattel's Astronaut Barbie Becomes a Mars Explorer with NASA Help' collect SPACE.com Editor 05 August, 2013 12:39pm ET.

TURKEL, A. R. 1998. All about Barbie: Distortions of a transitional object. *Journal of The American Academy of Psychoanalysis*. 26(1), 165-177.

UNIFORM CIRCULAR MOTION

P. C. Agarwal

Professor of Physics

Regional Institute of Education,
National Council of Educational Research and Training, Ajmer

Introduction

The concept of displacement as a vector quantity and the methods of adding and subtracting vectors are used to study motion of objects in two and three dimensions. Normally motion in two dimensions is studied first and then extended to three dimensions. Motion using general vector notations without separating it into two and three dimensions. It would therefore be valid for both the cases.

We begin with the concept of average velocity (an extension of the one-dimensional case, where one has to consider as many components as there are dimensions):

$$\vec{v}_{av} = (\vec{r}_2 - \vec{r}_1) / (t_2 - t_1) \equiv \Delta \vec{r} / \Delta t \quad (1)$$

Where $\Delta \vec{r}$ or $(\frac{\Delta y}{\Delta x})$ is the displacement (from position \vec{r}_1 to \vec{r}_2) that occurs in a time interval Δt or $(t_2 - t_1)$.

In two and three dimensions, the average speed over any time interval will usually be greater than the magnitude of the average velocity over the same time interval since the actual path of the object between the end points of the displacement is curved. For example in a circular path (1/2 complete revolution) distance covered is $2\pi r$ while displacement covered is $2r$ as it is clear

from Fig. 1. Thus distance \rightarrow displacement and therefore speed \rightarrow velocity.

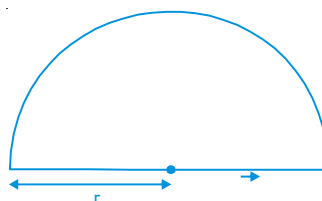

Fig.1

Comparison or order relation exists for similar quantities only. For scalars there is no order relation but for vectors order relation is there, e.g. $\vec{A} > \vec{B}$ or $|\vec{A}| \rightarrow |\vec{B}|$.

How do average speed and average magnitude of velocity compare in one dimension? The students and even teachers have a tendency to take them to be equal. Let them consider various kinds of one-dimensional motion and discover that the equality is not always valid.

Instantaneous velocity is defined as usual using the limiting procedure:

$$V = \lim_{\Delta t \rightarrow 0} (\Delta \vec{r} / \Delta t) = d\vec{r} / dt = v(t). \quad (2)$$

This has no direct experimental significance in kinematics. If an object is traveling along a curve in a plane or in a three-dimensional space, the instantaneous velocity at any point on the path has

the direction of the tangent line at that point.

Acceleration is again an extension of the corresponding expression in one dimension

$$\vec{a} = \lim_{\Delta t \rightarrow 0} (\Delta \vec{v} / \Delta t) = d\vec{v} / dt \quad (3)$$

Analogous to equations for one dimension, kinematics equations for two and three-dimensional motion with constant acceleration \vec{a} are

$$\vec{v} = \vec{v}_0 + \vec{a}t, \quad (4)$$

$$v^2 = v_0^2 + 2\vec{a} \cdot (\vec{r} - \vec{r}_0), \quad (5)$$

$$\vec{r} = \vec{r}_0 + \vec{v}_0 t + \vec{a}t^2 / 2. \quad (6)$$

Common misconceptions

- Students often think that $\Delta \vec{r}$ is in the same direction as \vec{r} and $\Delta \vec{v}$ is in the same direction as \vec{v} , most likely an incorrect extension of the idea in one dimension. On further extrapolation, these would mean that \vec{v} is in the same direction as \vec{r} and \vec{a} is in the same direction as \vec{v} which are not true in general in two and three dimensions.

This can be rectified with the help of Fig. 2 in which \vec{r} and $\Delta \vec{r}$ have been shown in a general case. They have clearly different directions.

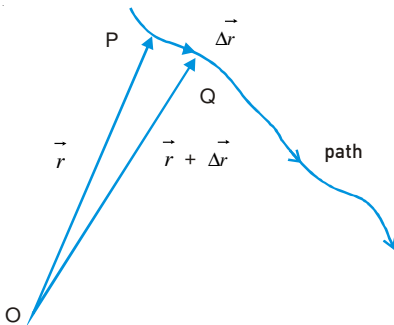

Fig.2

Here P and Q are the positions (described by the vectors \vec{r} and $\vec{r} + \Delta \vec{r}$) of the body at instant t and $t + \Delta t$ respectively along the path indicated. By the triangle law of vector addition $\vec{OQ} = \vec{OP} + \vec{PQ}$

With reference to this diagram and using their knowledge of vector algebra, the students should be able to show that if \vec{v} and $\vec{v} + \Delta \vec{v}$ be the velocities of the body at P and Q respectively. $\Delta \vec{v}$ and hence \vec{a} will have a direction different from that of \vec{v} .

From this they should conclude that in general, a vector \vec{A} and its time derivative $d\vec{A}/dt$ need not point in the same direction. The students should also recognize that the line representing position $\vec{r} + \Delta \vec{r}$ is not necessarily longer than that representing position \vec{r} in spite of the positive sign in the former expression.

Another interesting feature they may note is that in order to describe a motion in two dimensions, four initial conditions (initial position and initial velocity) are needed. The number increases to six in three dimensions, and reduces to two in one dimension. Let the students discover these numbers using their knowledge of vectors and their components.

Uniform Circular Motion

At higher secondary level, uniform circular motion is usually studied as an example of a periodic or repetitive motion in a plane, neglecting the gravitational attraction of the earth. This simple ideal motion introduces important concepts like those of *centripetal* and *centrifugal* forces. It is

observed that students as well as teachers have a number of conceptual problems and alternative conceptions in this case. We had glimpses of some of these in our interaction with students and teachers. Some studies have also discovered other hard spots and alternative conceptions.

Hard Spots

Common hard spots for students include linear velocities (tangential/radial), axis of rotation, the concept of angular speed vis-à-vis angular frequency and vectorial nature of angular displacement and angular velocity.

Alternative Conceptions

- Uniform circular motion means *constant velocity* along a circle.
- A particle or a body executing uniform circular motion is *in equilibrium*.
- Tension (in the string to which the rotating body is tied) *balances* the centripetal force.
- Centrifugal force *cancels* or *balances* the centripetal force.
- Centrifugal forces are *real i.e. the effects are real*.
- An object moving in a circle with constant speed has *no or zero* acceleration.
- An object moving in a circle will continue in *circular motion* when released.
- An object in circular motion will fly out *radially* when released.

Remedial Suggestions

Here we would like to discuss some aspects of uniform circular motion keeping in mind the hard spots and alternative conceptions noted above.

We consider a particle traveling round a circular path of radius r with a constant speed v . This constitutes an example of uniform circular motion. It is important for the students to note that it is not a case of constant velocity or constant acceleration. The particle takes a time T (measured in s), called the period of the motion, to go once round the circle. Obviously the line joining the position of the particle to the centre of the circular path sweeps out the angle of 2π radians (rad) in time interval T and so an angle of $2\pi/T$ radians per second or rad s^{-1} . This is defined as the angular speed or angular frequency ω of the particle. Though the unit of angular speed is rad/s , the second name of ω (angular frequency) is also appropriate, considering the fact that *rad* is a dimensionless unit. Both the names of ω are used in literature. In fact, some call it angular velocity too without caring for the distinction between scalar and vector. Clearly ω as defined above is a scalar constant and is given by

$$\omega = 2\pi/T = 2\pi/(2\pi r/v) = v/r$$

Here v is also the magnitude of instantaneous velocity. The students ought to recognise that these are the characteristics of a uniform circular motion and they need not worry about vectors like position vector, linear velocity, angular velocity, etc. to begin with. First, they should be able to form a mental picture of these quantities r , n and ω and show them on a planar diagram depicting the uniform circular motion. This will help them understand the respective vectors \vec{r} , \vec{v} and $\vec{\omega}$ as and when they appear.

We shall now introduce these quantities as vectors using the concepts that have already been developed while dealing with two-dimensional motion in this section. The approach would not

only consolidate the students' concept of vectors but would also bring out the vectorial nature of the various quantities clearly. This may be used in conjunction with the treatment available in standard textbooks.

We shall refer to Fig. 3 for uniform circular motion where both the Cartesian (x, y) and plane polar coordinates (r, θ) have been shown in (a) and their respective unit vectors in (b). O is the observer of the motion stationary at the centre of the circle.

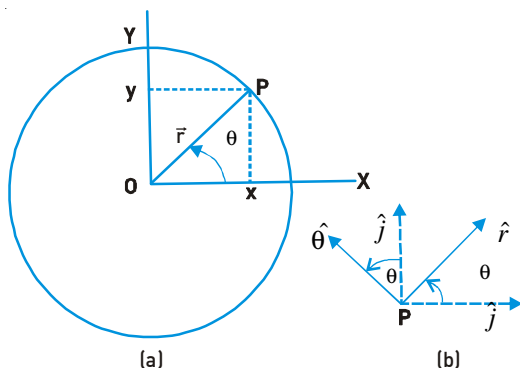

Fig. 3

Here it is to be noticed that

1. A uniform circular motion is an accelerated motion.
2. When centripetal force is zero, a body cannot move on a circular path.

It is not necessary to show everything in one diagram as it is likely to make the diagram look clumsy and inconvenient. For better clarity and convenience, students should be encouraged to draw as many diagrams as required.

With reference to Fig.3 (b) we have

$$\hat{r} = \hat{i} \cos \theta + \hat{j} \sin \theta, \text{ and} \quad (7)$$

$$\hat{\theta} = -\hat{i} \sin \theta + \hat{j} \cos \theta. \quad (8)$$

since $\vec{r} = r\hat{r}$, the velocity vector becomes

$$\begin{aligned} \vec{v} &= \frac{d\vec{r}}{dt} = r \frac{d\hat{r}}{dt} = r \frac{d\hat{r}}{d\theta} \frac{d\theta}{dt} = r\omega \frac{d\hat{r}}{d\theta} \\ &= r\omega\hat{\theta} = v\hat{\theta} \end{aligned} \quad (9)$$

Where, we have used the fact that $\omega = d\theta/dt$ and $\frac{d\hat{r}}{d\theta} = \hat{\theta}$ [from equations (7) and (8)]. Clearly, equation (2c) implies that velocity in this case is purely tangential (denoted by $\hat{\theta}$) in nature and has no radial component (why?). Next, the acceleration vector is given by

$$\begin{aligned} \hat{a}_{cp} &= \frac{d\vec{v}}{dt} = v \frac{d\hat{\theta}}{dt} = v \frac{d\hat{\theta}}{d\theta} \frac{d\theta}{dt} = v\omega \frac{d\hat{\theta}}{d\theta} \\ &= -v\omega\hat{r} = -a\hat{r} \end{aligned} \quad (10)$$

In which $d\hat{\theta}/d\theta = -\hat{r}$ [from equations (2a) and (2b)]. Clearly, equation (2d) implies that acceleration is radial and points towards the centre. This is the centripetal acceleration whose magnitude is $a = v\omega = v^2/r = \omega^2 r$. If m be the mass of the particle, then the force acting on the particle is the centripetal force \vec{F}_{cp} that is given by the formula

$$\vec{F}_{cp} = m\vec{a}_{cp} = -m\hat{r} = -(mv^2/r)\hat{r} = -(m\omega^2 r)\hat{r} \quad (11)$$

It is important to recognise that this is the force that must act on the particle in order to keep it moving uniformly in the circular path.

The observer O therefore concludes that \vec{F}_{cp} is the net force that acts on the particle, and hence, the particle is not in equilibrium by definition. It thus follows that uniform circular motion cannot occur without force, unlike uniform rectilinear motion for which no force is needed (first law of motion).

The point is, there must be some source or agent to supply the force \vec{F}_c . The agent may be the tension in the string tied to a rotating stone or the gravitational attraction of the sun in case of a planetary body, e.g. a vehicle moves uniformly on a circular level road, it is the frictional force between the tyres of the vehicles and the road that provides the necessary centripetal force.

The agent thus *supplies or provides* the centripetal force necessary for the circular motion. It *does not cancel* the centripetal force as is often thought. If it were to cancel the centripetal force the net force would be zero and particle will move in a straight line, which will contradict the conclusion stated in the previous box.

Let us now look at the motion of the particle from a different perspective. Let the observer O rotate together with the particle at the same uniform rate w . Clearly, the particle is at rest and in equilibrium relative to this observer; this means that a force equal in magnitude to the centripetal force and opposite in direction must be acting on the particle along with the centripetal force. The new force

$$\vec{F}_{cf} = -\vec{F}_{cp} = -m\vec{a}_{cp} = m\vec{a}_r = (mv^2 / r)\hat{r} = (m\omega^2 r)\hat{r} \quad (12)$$

is termed the centrifugal force. Let us consider a situation in which two passengers are sitting side by side in a bus. One of them is sitting rather 'tightly' holding on to the frame of the seat, whereas the other passenger is sitting 'loosely'. Then the bus takes a sharp turn to the left. The first passenger will observe that his companion is shifting on the seat away from him towards the right. This is an effect of the centrifugal force, which we might have experienced on several

occasions without realising it. The first passenger's head might also tilt to the right because by rigid structures fixed to the seat frame, then the effect of the centrifugal force cannot be 'observed' unlike with human beings, but it will still exist in the frame of reference of the bus when it takes a turn.

From this discussion it becomes clear that centrifugal force has interesting and unique characteristics:

- (i) Centrifugal force and centripetal force do not constitute an action-reaction pair because they act or supposed to act on the same body as observed from a rotating frame (observer O) or a non-inertial frame of reference. In such a frame, these two forces may be said to cancel each other as we saw above.
- (ii) Centrifugal force exists in a non-inertial frame of reference and has no existence in an inertial frame (observer O).
- (iii) Centrifugal force does not arise from any interaction unlike the centripetal force, which needs to be provided from interaction with an agent such as the string.
- (iv) For reasons such as above, centrifugal force is often termed a 'pseudo-force' or 'fictitious force'. However, its effect can be *real* and *seen* by an observer in a non-inertial frame of reference. Recognizing these would help rectify misconceptions regarding centrifugal force.

The interesting question of 'what happens when a body in circular motion is released' is answered by noting that for an observer like O (in an inertial frame of reference), the body becomes free as no force is acting on it now, and as is well known.

Newton's first law of motion takes over. The students should be encouraged to work out the rest leading to the answer. It would be interesting and instructive for the teacher to first work out the case when the observer would continue to rotate (like the observer O') after the body is released, and then instruct the students accordingly.

In our discussion so far we have not used the vectorial nature of quantities like angular displacement and angular velocity and the concept of axis of rotation, which are not adequately understood by the students. But they have their own importance. Angular velocity is denoted by the vector $\vec{\omega}$ whose magnitude ω is called angular speed or angular frequency. By convention, direction of $\vec{\omega}$ is defined by the *right hand rule*. Let the right hand be curled such that the fingers point in the direction of rotation of the particle (clockwise or anticlockwise). $\vec{\omega}$ will then be taken to point in the direction of the extended thumb. The direction of the extended thumb is also taken to represent the axis of rotation. The same conclusion may also be reached by using the familiar *right hand screw rule*. Let the students verify this.

If we write $\vec{\omega} = \omega \hat{\omega}$, then $\hat{\omega}$ will lie along the axis of rotation and will be given by the right hand rule. Since $\omega = d\theta / dt$ and angular velocity is defined as the rate of change of angular displacement (analogous to the case of rectilinear motion), we can define the angular displacement vector $\vec{\theta} = \theta \hat{\omega}$. It is important to note that it is $\hat{\omega}$ and not $\hat{\theta}$ [$\hat{\theta}$ gives the direction of the tangential velocity \vec{v} as in equation (9) that gives the direction of $\vec{\theta}$]. The students should verify that $\vec{\theta}$ is actually a vector in two dimensions since (i) it has both magnitude and direction, and (ii) it obeys the commutative law of vector addition.

The students ought to recognise that (i) above is just a necessary but not sufficient condition for a quantity to be termed a vector. It has to satisfy condition (ii) also.

This should not, however, generalize the vectorial nature of $\vec{\theta}$ from two to three dimensions since the commutative law of vector addition is not valid for finite angular displacements in three dimensions. (Let the students actually verify this.) Nevertheless infinitesimal angular displacements (like $d\theta$) satisfy the requirement of commutativity and therefore qualify as vectors in three dimensions.

We have now three vectors associated with uniform circular motion: \vec{r} , \vec{v} and $\vec{\omega}$. Let the students do the exercise of finding the vectorial relationship among them using the well known relation $\vec{v} = \vec{r}\omega$.

We may thus note that uniform circular motion or rotational motion is unlike the case of uniform rectilinear motion and is replete with many interesting and intriguing features. This encourages us to compose a *six-line limerick* as follows:

Mr. Particle' takes a ride,
Glee and surprises he can hardly hide.
He goes straight and yet turns left,
Moves uniformly and still accelerate.
Loose in seat, he's pushed to right;
Cut loose, becomes Newton's delight

The limerick may be used as a teaching learning aid by the teacher and students alike as hidden in it are important concepts of rotation.

Conclusion

In this section, we have discussed some important aspects of motion in two and three dimensions with the objective of helping teachers develop the correct concepts in the learners. Uniform circular motion has been discussed in some detail as an example of two-dimensional motion. Learners' hard spots and alternative conceptions have been pointed out. This may be fruitfully used along with conventional textual material. The students ought to realise that mental imagery of three-dimensional

space as well as the skill of representing a three-dimensional motion on the plane of paper are required for developing the right concepts. The teacher can definitely do her/his bit for this.

Acknowledgments

Author is grateful to Professor V.G. Jadhao, former Principal, RIE, Ajmer and Professor B.K. Parida, RIE, Bhubaneswar for their valuable suggestions and critical review of this article.

References

- FINLEY, F.N., J. STEWART AND W.L. YARDOCH. 'Teachers' perception for important and difficult science content, *Science Education*. 66(4) (1982) pp. 531-538.
- JAYSHREE RAMADAS, SHIRISH BARVE and ARVIND KUMAR. 'Alternative Conceptions in Galilean Relativity: Inertial and Non-inertial Observers. *Int. J. Sc. Edu.* Vol. 18, No. 15, (1996) pp. 615-629.
- _____. Alternative Conceptions in Galilean Relativity. *International Journal of Science Education*. Vol. 18, No. 4, (1996) pp. 463-477.
- JEAN-LUC DUGELAY AND HENRI SANSON. Differential Methods for the Identification of 2D and 3D Motion Models in Image Sequences'. *Signal Processing:Image Communication*. Vol. 7, Issue 1 (1995). pp. 105-127.
- MCCLOSKEY, M. AND D. KOHL. 'Naïve Physics: The Curvilinear Impetus Principle and its Role in Interactions with Moving Objects'. *Journal of Experimental Psychology: Learning, Memory and Cognition*. 9 (1) (1983) pp.146-156.
- P. SEARLE. 'Circular Motion: Concepts of First Year Engineering Students'. *Research in Science Education*. 1(2) (1985). pp. 140-150.
- PANSE, S., J. RAMADAS AND A. KUMAR. Alternative corrections in Galilean Relativity-Distance, Time, Energy and Laws', *International Journal of Science Education*. Vol. 16 no.1 (1994). pp. 63-82.
- ROBERT RESNICK, DAVID HALLIDAY, KENNETH S. KRANE. 2001. *Physics* (5th ed.). Wiley. Volume 1, Chapter 3.
- WARREN, J.W. 'Circular Motion'. *Physics Education*. 6 (1971). pp.74-77.
- WHITELY, P., 'Students' Difficulties with the Force(s) Acting on the Moon'. *Physics Education*. 30 (1995). pp. 31-33.

EFFECT OF CONCEPT MAPPING STRATEGY ON ACHIEVEMENT IN ORGANIC CHEMISTRY OF CLASS XII SCIENCE STUDENTS

Kanak Sharma

Research Scholar

Faculty of Education

Kamachha, BHU, Varanasi 221010

Introduction

Chemistry is often full of abstract concepts resulting from its inherent complex nature. It may lead to extensive misconceptions among students (Gable, 1999). It is also a common problem in chemistry that even if students do well in examinations, they still may fail in solving basic textbook problems, which is a sign of rote learning (Pendley et al., 1994).

It is important to find various new as well as interesting ways that can lead towards meaningful chemistry learning. One way to accomplish this, is to apply Ausubel's theory of meaningful learning. Concept maps were devised as a device of meaningful learning which can be regarded as the counter and effective replacement of rote learning.

The use of concept map has been widely investigated in the field of chemistry. According to Francisco et al., (2002) and Nicoll et al., (2001), concept maps are a useful learning tool in chemistry. Concept maps can improve understanding of chemical concepts and help build connections among abstract concepts. Concept maps can also be used as a misconception correction tool. These concept

maps bind concepts with linking words that help students see connections among them and organise their knowledge hierarchically, based on scientific knowledge. (Francisco et al., 2002; Nicoll et al., 2001)

Concept maps are spatial representations of concepts and their interrelationships that are intended to represent the knowledge structures that human stores in their minds (Jonassen, Beissne and Yacci, 1993). The use of concept maps as teaching strategy was first developed by Joseph D. Novak of Cornell University in the early 1980's. His Work was based on important idea in Ausubel's (1968) assimilation theory of cognitive learning which places central emphasis on the influence of students' prior knowledge on subsequent meaningful learning.

Concept maps are diagrammatic representations which show meaningful relationships between concepts in the form of propositions which are linked together by words, circles, and cross links. Concepts are arranged hierarchically with the super ordinate concepts at the top of the map, and subordinate at the bottom which are less inclusive than higher ones. "Cross links" are used to connect different segments of the concepts

hierarchy which indicate syntheses of related concepts, a new interpretation of old ideas, and some degree of creative thinking.

This research paper presents the outcome of an investigation to study the use of concept mapping as a teaching strategy to enhance meaningful learning and to improve achievement of students in Organic Chemistry.

Objectives of the Study

- To develop Concept maps of 2 concepts from selected one unit of Organic Chemistry syllabus prescribed by the C.B.S.E. Board for Class XII science students.
- To study the effectiveness of Concept Mapping Strategy in comparison to the Lecture Method in terms of achievement of Class XII science students in Organic Chemistry.
- To study the effectiveness of Concept Mapping Strategy in comparison to the Lecture method in terms of concept retention of Class XII science students in Organic Chemistry.

Design and Sample of the Study

The study was quasi-experimental in nature where Pre-test Post-test Non-equivalent Groups Design was used. The total 80 science students of two intact sections that is 'A' and 'B' of Class XII from Central Hindu Boys School of Varanasi city, were chosen as the sample of the study. Out of these two sections, section 'A' was randomly assigned as the experimental group ($n_1=40$) and other section 'B' as the control group ($n_2=40$) for the study (see Table 1).

Table 1 : The groups involved in the study and the number of students

Groups	Number of Students (N)
Experimental Group (Concept Mapping Strategy)	40
Control Group (Lecture Method)	40
Total	80

Tools Used in the Study

Twelve Concept maps of 2 concepts from selected one unit of Organic Chemistry syllabus prescribed by the C.B.S.E. Board.

Mixed Group Test of Intelligence (Hindi Version) by Dr P.N. Mehrotra, Verbal and Non-verbal Test was used for equating the both groups i.e. experimental and control groups on the basis of their intelligence scores.

An Achievement test consisting of 25 multiple-choice questions based on 2 concepts from selected one unit of Organic Chemistry syllabus prescribed by the C.B.S.E. Board for Class XII science students was developed by the investigator to measure the students' achievement and concept retention in Organic Chemistry. In this test each question carries one mark. The achievement test served as both pre-test and post-test (post-test I and post-test II).

Procedural Details of the Study

In the present study the investigator introduced 2 concepts of selected one unit namely; Phenol and Ether through 12 concept maps regarding various aspects such as preparation, properties, reactions and interconversions were developed by the investigator.

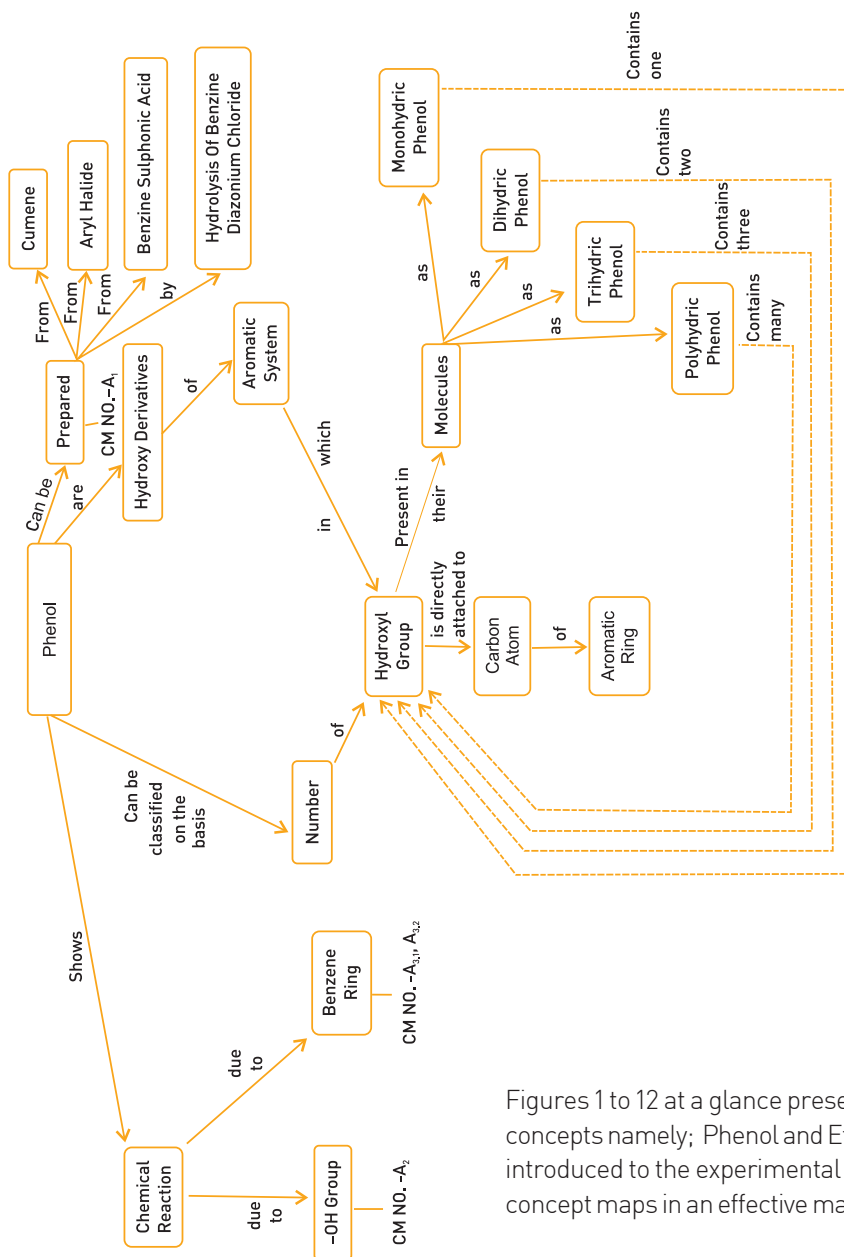

Fig. 1

Figures 1 to 12 at a glance present, how 2 concepts namely; Phenol and Ether were introduced to the experimental group through concept maps in an effective manner.

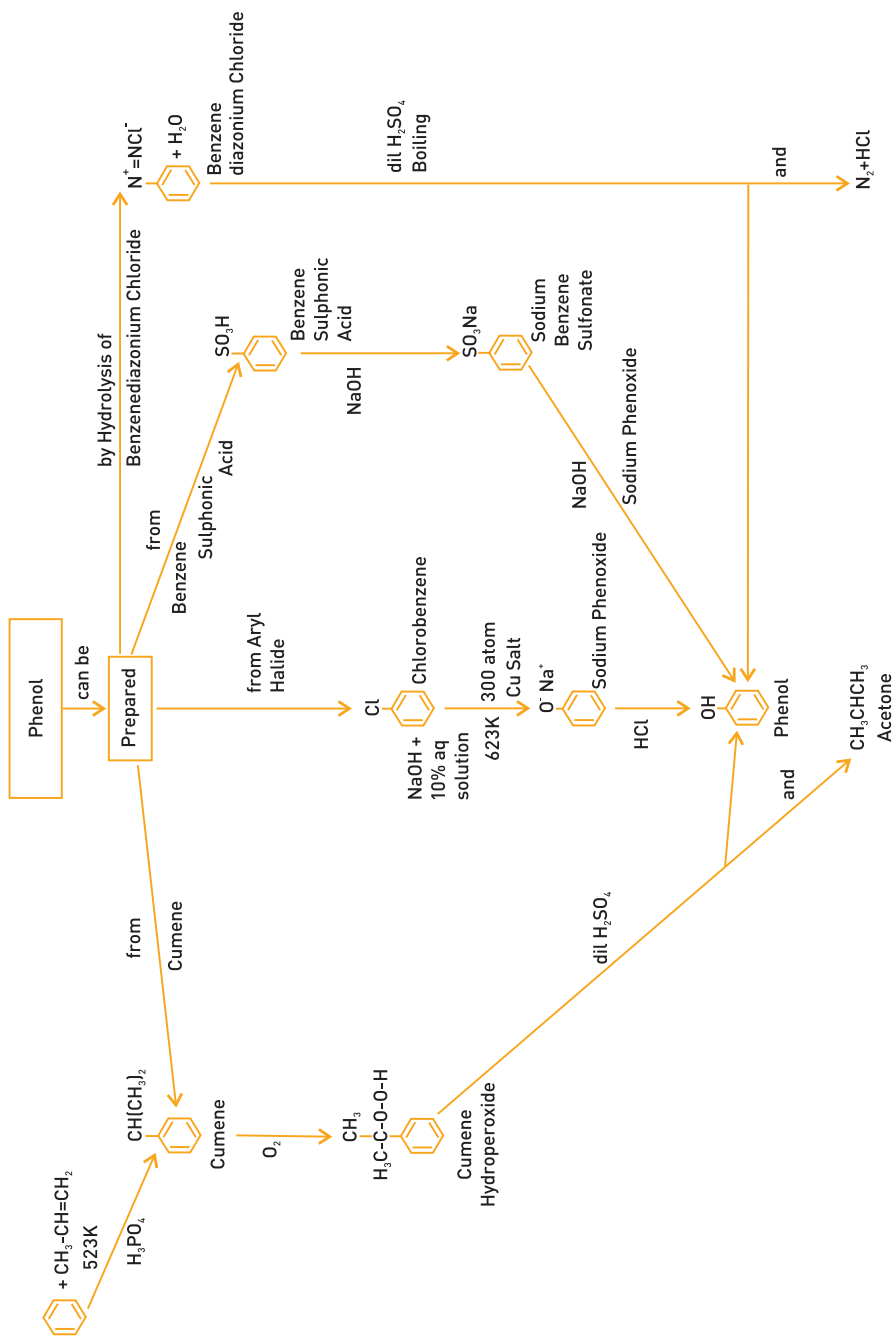

Fig. 2

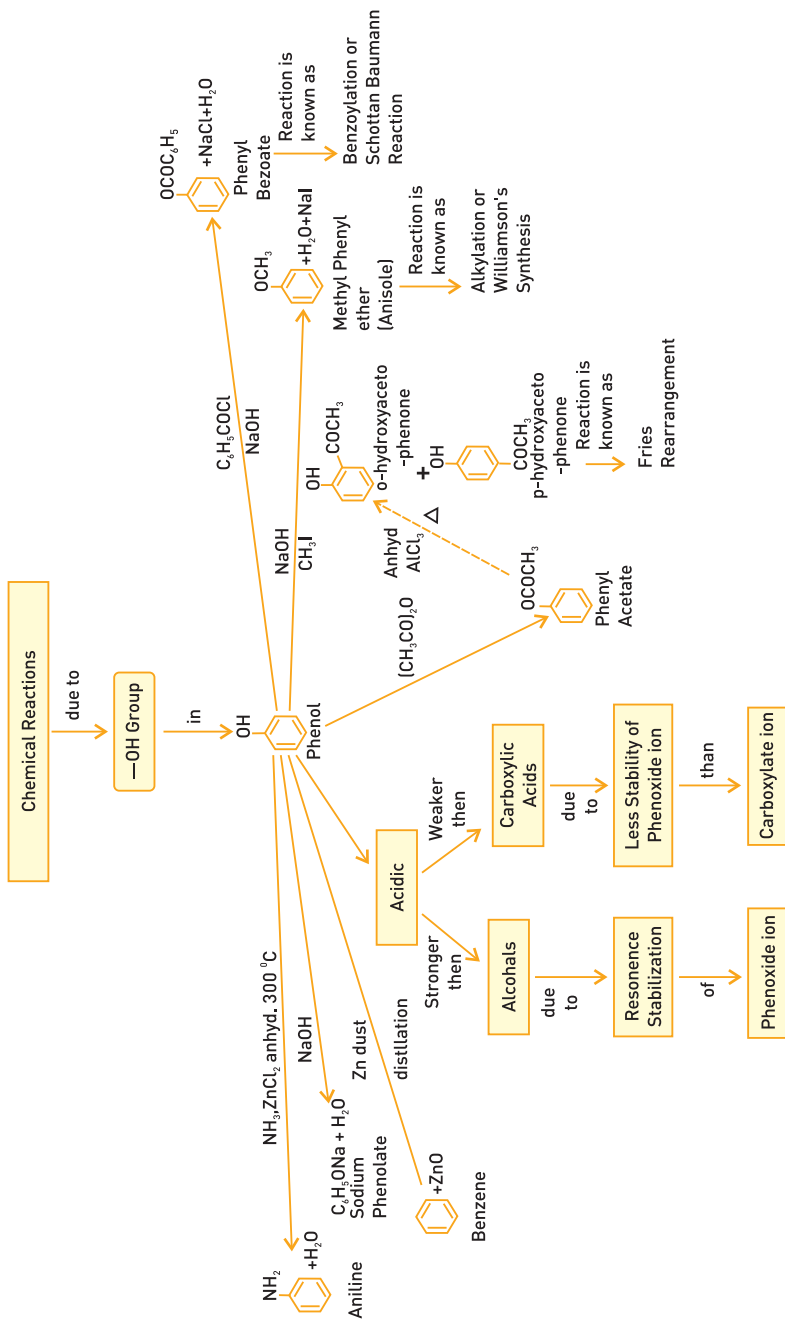

Fig. 3

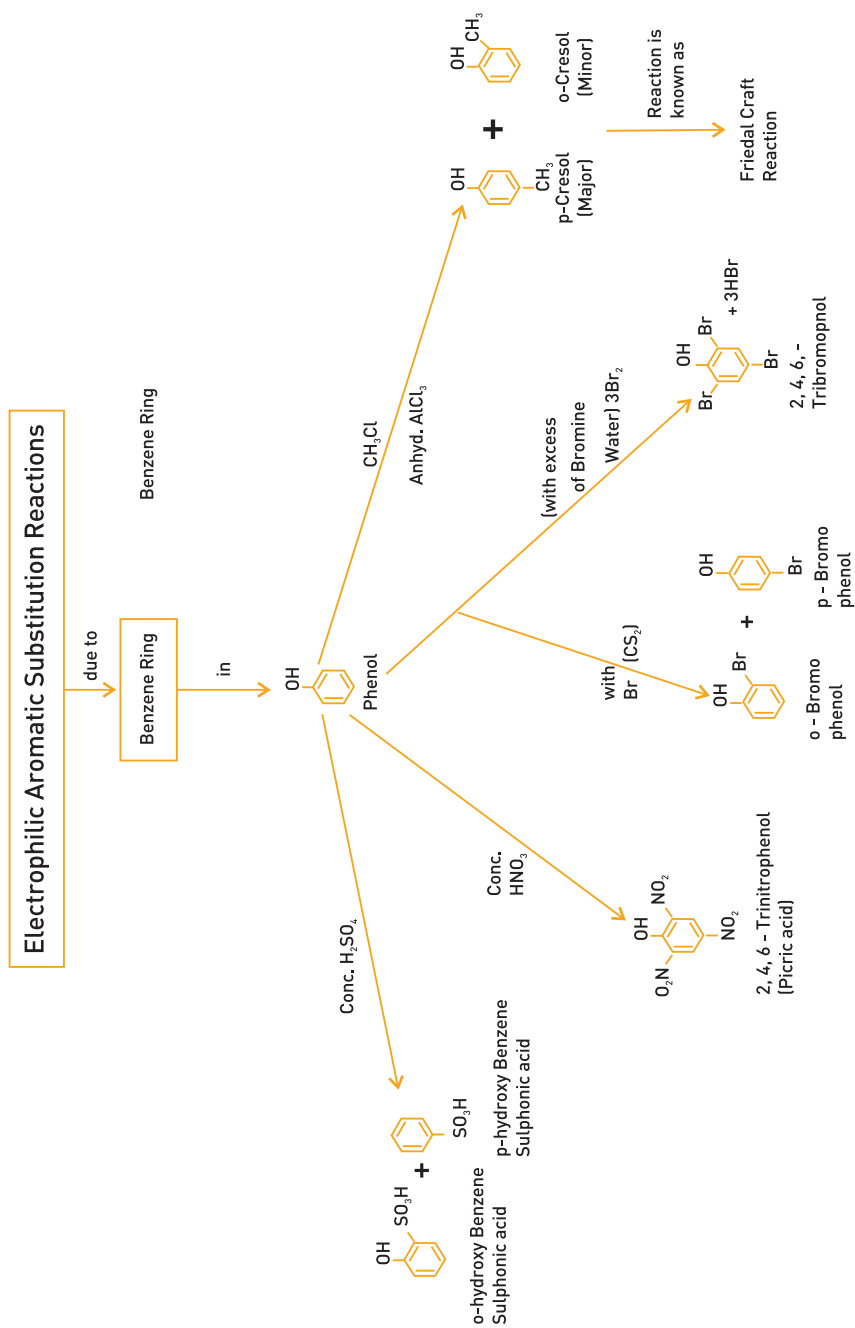

Fig. 4

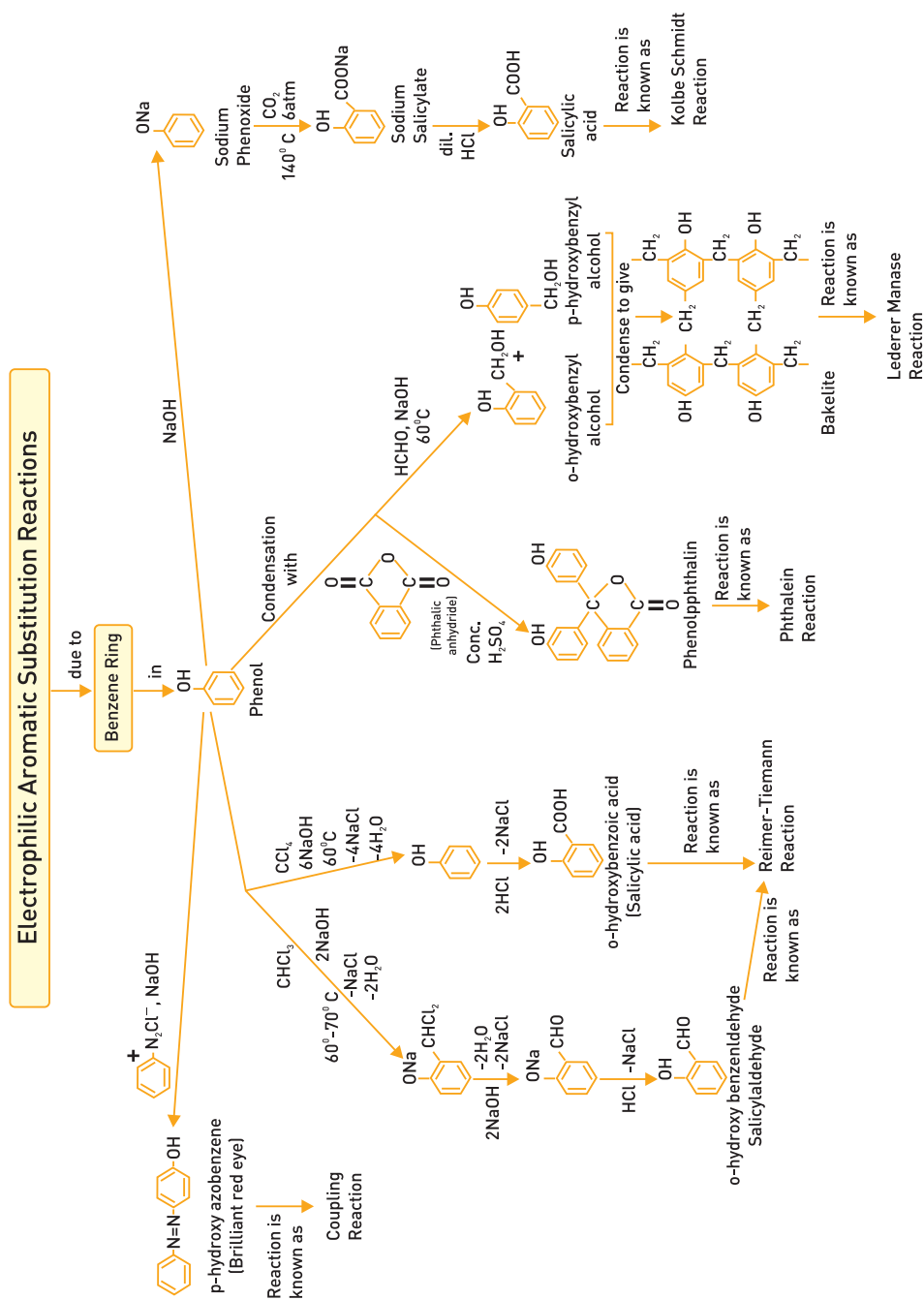

Fig. 5

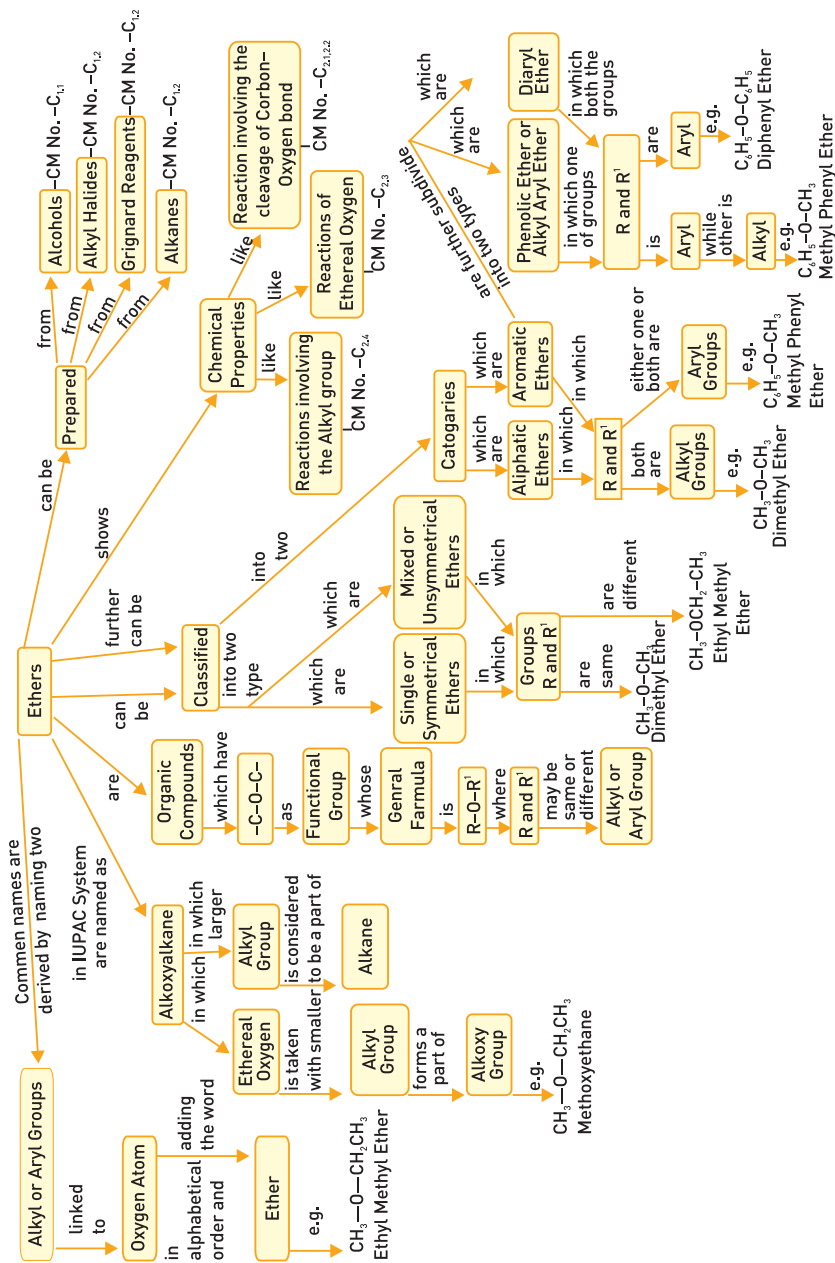

Fig. 6

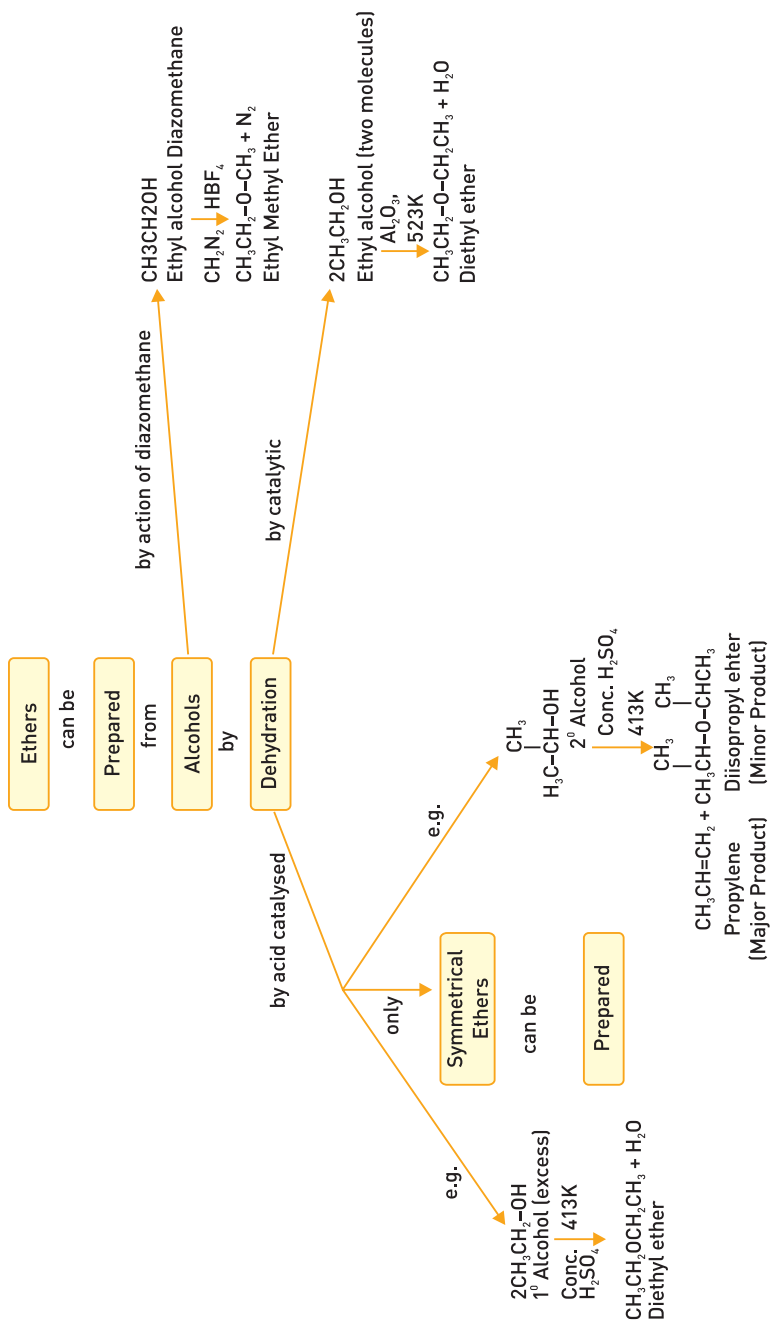

Fig. 7

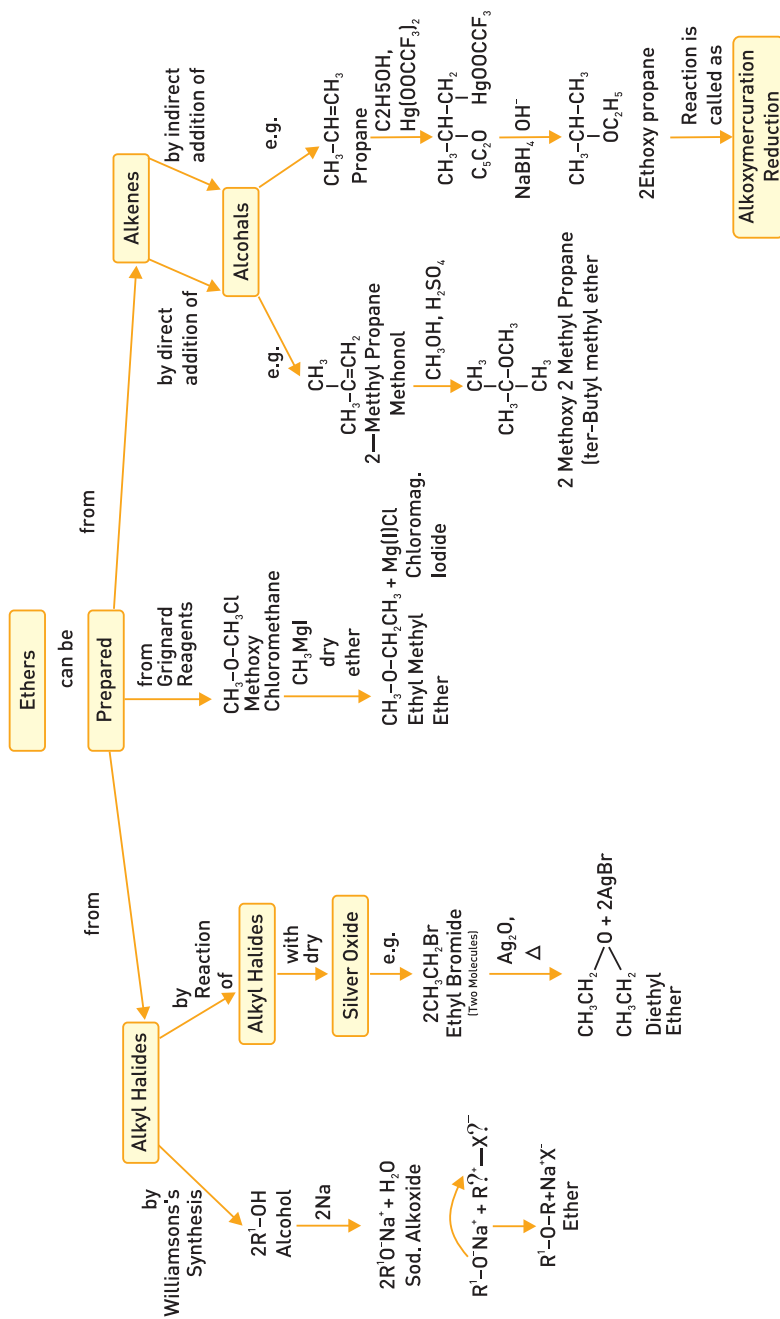

Fig. 8

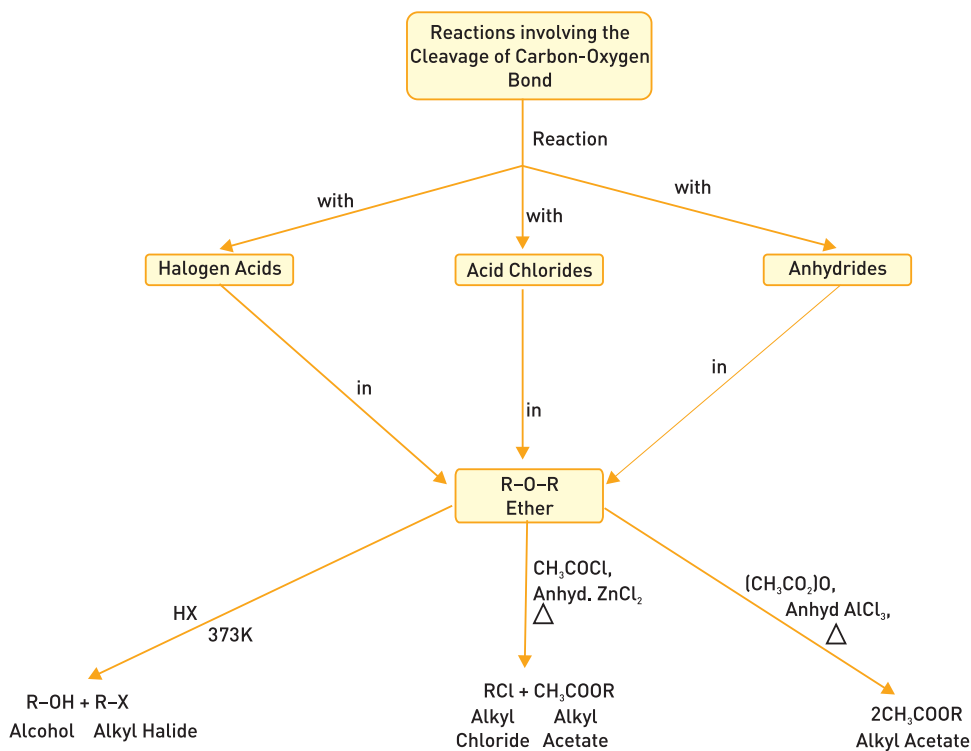

Fig.9

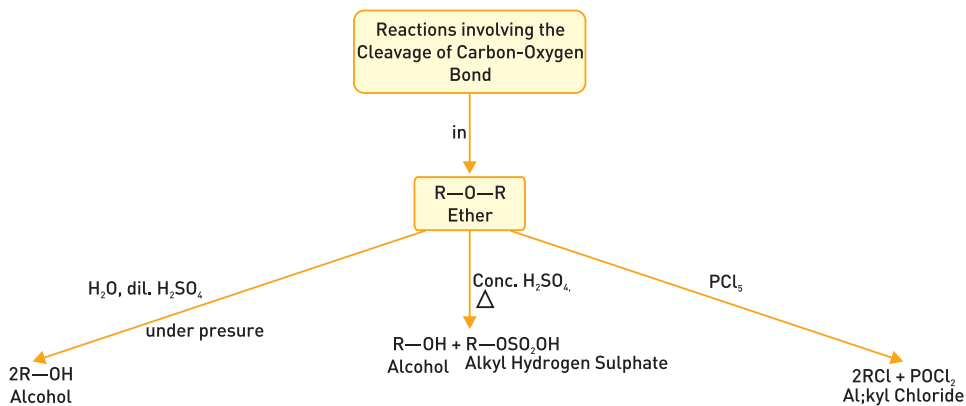

Fig.10

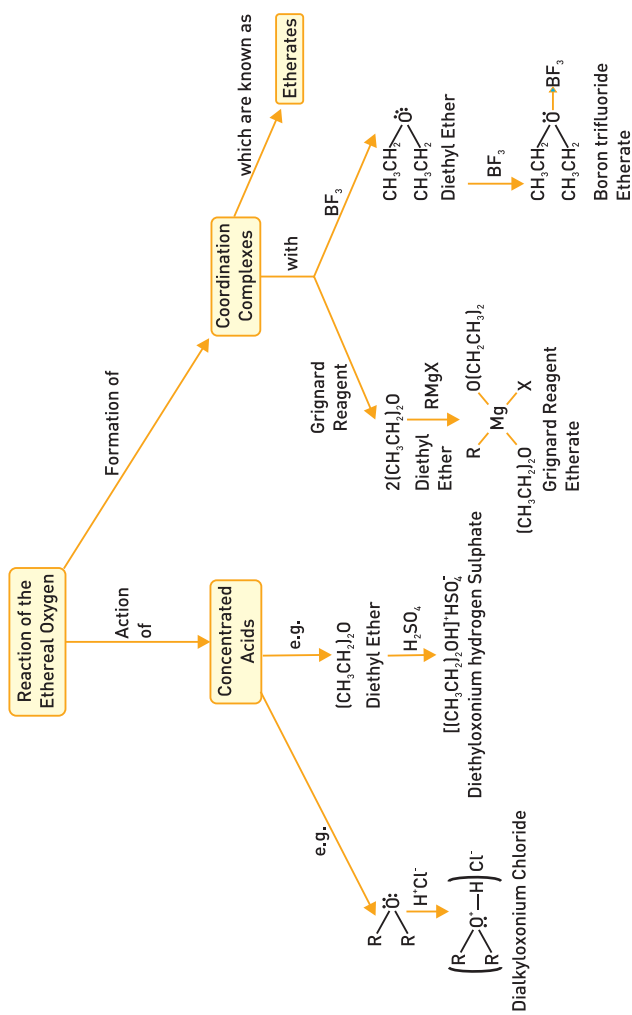

Fig. 11

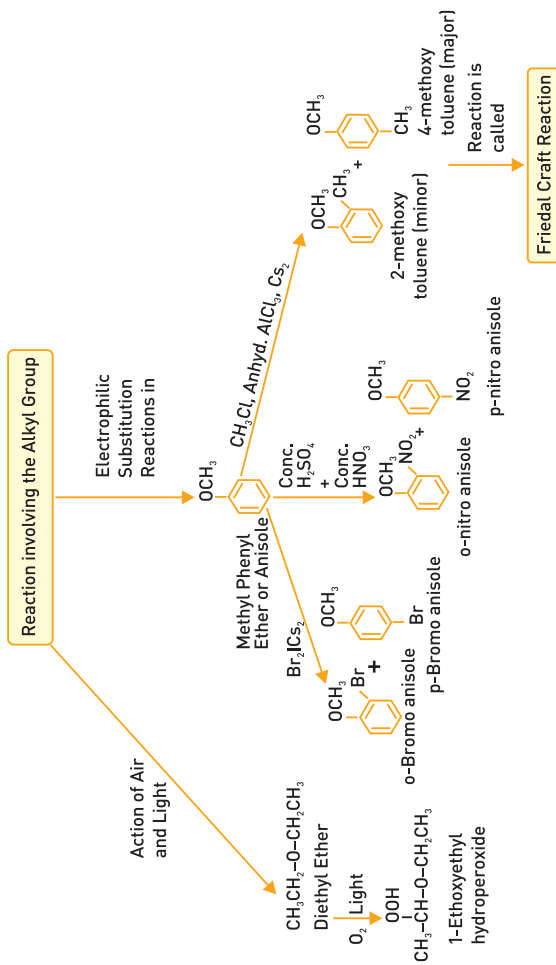

Fig. 12

The tool was tried out and item analysis was carried out in case of achievement test. The study's research pattern is given below in Table 2.

Table 3 reveals that "t" value of 0.258 for intelligence scores were not significant at 0.05 level. It meant that the both groups had almost the same intelligence level. After this the standardised

Table 2 : The Study's Research Pattern

Groups	Pre-Treatment	Treatment	Post-Treatment	Delayed Post-Treatment (After a gap of six weeks)
Experimental Group	I, T	Taught the selected concepts through Concept Mapping Strategy	T T	T T
Control Group	I, T	Taught the selected concepts through Lecture Method	T	T

The experimental group in Table 2 represents the group of students which was taught through Concept Mapping Strategy (CMS) and the control group represents the group which was taught through Lecture Method (LM). I shows the Intelligence Test, T shows the Organic Chemistry Achievement Test (Pre-test and Post-test (I and II)).

Before starting the experiment the investigator administered a Mixed Group Test of Intelligence on both experimental and control group. These two groups (experimental and control) are naturally assembled groups as intact classes, which may be similar. The subjects were not matched on the previous achievement in organic chemistry but were equated on the basis of their intelligence scores. "t" test was applied for matching the groups and results have been given below in Table 3.

Table 3 : Mean, S.D., and 't' values of Intelligence scores for Experimental group and Control group

Groups	N	Mean	S.D.	't'	p
Experimental Group	40	59.34	11.34	0.258	→0.05
Control Group	40	60.02	12.22		

achievement test was administered as pretest on both experimental and control group.

However, after the pretest the control group was taught through Lecture method and the experimental group was taught through Concept Mapping Strategy. In order to avoid the impact of teacher effectiveness both groups were taught by the same teacher (The investigator). After teaching all 12 concepts Post-test I was administered on both groups and after a gap of six weeks from the treatment each group was posttested again on Post-test II (delayed posttest) for measuring their concept retention. The data obtained was analysed descriptively and inferentially by calculating ANCOVA, Mean_{Gain}, S.D., & "t" values.

Result and Discussion

Effect of Concept Mapping Strategy on Achievement in Organic Chemistry

Ho1 : There is no significant difference between means of achievement scores of students taught through Concept Mapping Strategy and students taught through Lecture Method.

Table 4 : Summary Table of Analysis of Covariance (ANCOVA) showing Pre-test Post-test scores of Experimental and Control groups with respect to Achievement

Groups	Pre-test mean	Post-test Mean	Adjusted mean Difference	Source of Variation Squares	Sum of Squares	df	Mean Sum of	$F_{y,x}$	p
Experimental Group	6.22	13.63	0.1	Among Means	504.40	1	504.40	117.30	$\leftarrow 0.01$
Control Group	6.12	8.48		Within Groups	330.74	77	4.30		

A reference to Table 4 reveals that the obtained $F_{y,x}$ ratio after adjusting pretest differences into posttest was found to be 117.30 at dfs 1/77, which is significant at 0.01 level of confidence. It meant that experimental group differ from pretest to posttest on achievement test in Organic Chemistry. The above Table further shows that the mean post-test scores of experimental group was found to be higher than that of post test scores of control group. So, it can be concluded that the Concept Mapping Strategy is significantly more effective than the Lecture Method in the improvement of achievement in Organic Chemistry of Class XII science students. The findings of this study is on the same track as Kumuda (2000), Aparna (2002), Rao (2004), Candan, Turkman and Cardak (2006), Chiou and Chang (2008) and Demirdover et. al (2008). These researches have also studied the comparative effectiveness of Concept Mapping Strategy with respect to the traditional method in different subjects and at different levels.

Effect of Concept Mapping Strategy on Concept Retention in Organic Chemistry

Ho2 : There is no significant difference between the means of concept retention gain scores of

students taught through Concept Mapping Strategy and students taught through Lecture Method.

Table 5 : Mean_{Gain}, S.D. and 't' values obtained on Pretest and Delayed Post-test (Post-test II) Achievement in Organic Chemistry by Experimental group and Control group

Groups	N	Mean _{Gain} (Posttest II - Pretest)	S.D.	't'	p
Experimental Group	40	4.275	3.33	6.02	<0.01
Control Group	40	0.975	0.973		

A reference to the Table 5 reveals that there is a significant difference between the means of concept retention gain scores of students taught through Concept Mapping Strategy and students taught through Lecture Method. The above Table further shows that the mean concept retention gain score of experimental group is greater than the control group and the 't' value is significant at 0.01 level of confidence. On the basis of this result we can say that the Concept Mapping Strategy is significantly more effective than the Lecture Method for concept retention in Organic Chemistry.

To some extent, these results are supported by Gupta (1999), Ahuja (2006) and Parsa and Nikbakht (2004).

Gupta (1999) while specifically compared the relative effectiveness of the Concept Mapping Model, the Inductive Model and the Conventional Method to foster concept learning and concept retention in terms of comprehension and application of concepts in chemistry. She concluded that Concept Mapping Model and Inductive Model are significantly more effective than the Conventional Method to foster concept learning and concept retention in terms of comprehension and application of concepts in Chemistry.

Where as Heinze-Fry and Novak (1990) carried out a study on 40 students adopting Concept Mapping Strategy for one month covering three instructional units found that the mapping group achievement was high though not significant, in measure of initial learning, retention and learning efficiently.

Conclusion

Based on the result of this study, it can be concluded that the Concept Mapping Strategy is more effective for improving the achievement of students in Organic Chemistry and also more effective for concept retention in Organic Chemistry of Class XII science students when compared to the Lecture Method. Hence there is a

need to include Concept Mapping Strategy with the constructivist basis as one of the major approaches to teach Organic Chemistry in schools at 10+2 level. Use of Concept Mapping Strategy as a main route of teaching or as a complementary strategy for traditional teaching method may improve the students' achievement in Organic Chemistry and knowledge retention capability.

In the teaching learning process of Organic Chemistry, the use of Concept Mapping Strategy will be beneficial for teachers and as well as for students too. Students can use concept maps in Organic Chemistry for learning concepts, which they think are not clear, at the grass-root level. They can also use concept maps for summarising materials when preparing for examinations, for revision of content, for highlighting key concepts and for understanding relationships among them, for helping them to identify gaps in their knowledge, if any, and hence convincing them about the continuity of subject matter.

In Organic Chemistry remedial teaching can also be done by the teachers with the help of concept maps for example, students can be assigned the task of preparing the concept map on the topic to be discussed in subsequent classes. From these students based concept maps, the teacher can get the idea of students' previous knowledge and the existing misconceptions in Organic Chemistry. Once misconceptions in students' cognitive structure are diagnosed, remedial teaching in this direction can be done.

References

- AHUJA, AMIT. 2006. Effectiveness of Concept Mapping in Learning of Science. Unpublished Doctoral Dissertation. University of Delhi, Delhi.
- APARNA, C.F. 2002. The Effect of Concept Mapping as a Teaching Strategy and as an Evaluation Tool in Attainment of Science Concepts of Class V. Unpublished M.Ed. Dissertation, Regional Institute of Education., Mysore.
- AYSEL CANDAN, LUTFULLAH TURKMEN AND OSMAN CARDAK. 2006. The Effects of Concept Mapping on Primary School Students' Understanding of the Concepts of Force and Motion. *Journal of Turkish Science Education*. 3(1). 66-75.
- DEMIRDOVER C., M. YILMAZ, H. VAYWADA, A. ATABEY AND D. EYLUL. 2008. Comparison of Learning with Concept Maps and Classical Methods among Medical Students. *Proceedings of the Third Int. Conference on Concept Mapping*.
- FRANCISCO, J.S., M.B. NAKHLEH, S.C. NURRENBERN, AND M.L. MILLER. 2002. Assessing Student Understanding of General Chemistry with Concept Mapping. *Journal of Chemical Education*, 79(2). 248-257.
- GABEL, D. 1999. Improving Teaching and Learning through Chemistry Education Research : A Look to the Future. *Journal of Chemical Education*. 76(4). 548-553.
- GARRETT, HENRY E and R.S. WOODWORTH. 1981. *Statistics in Psychology and Education*. Vakils. Feffer and Simons Ltd., Bombay .
- GUPTA, V. 1999. Effectiveness of Concept Mapping in Comparison to Inductive Model in Science Education. Unpublished Doctoral Dissertation, University of Delhi, Delhi.
- HEINZE-FRY, J.A. AND J.D. NOVAK. 1990. Concept Mapping Brings Long Term Movement Towards Meaningful Learning. *Science Education*, 74(4). 461-472.
- JONASSEN, D.H., K. BEISSNER, AND M. YACCI. 1993. *Structural knowledge -Techniques for representing, conveying and acquiring structural knowledge*. Hillsdale, NJ: Lawrence Erlbaum Associates.
- Kumuda, G. 2000. A Comparative Study of Two Strategies namely; Concept Mapping Method and Lecture Method, Retrived on 10-9-2011 from <http://12freelance.com/articles/articles2622.html>.
- NICOLL, G., J.S. FRANCISCO. AND M. NAKHLEH 2001. An Investigation of the Value of Using Concept Maps in General Chemistry. *Journal of Chemical Education*. 78(8), 1111-1117.
- NOVAK, J.D. AND D.B. GOWIN. 1984. *Learning How to Learn*. Cambridge University Press, New York

PARSA, YEKTA Z. AND NIKBAKHT, A. NASRABADI. 2004. Concept Mapping as an Educational Strategy to Promote Meaningful Learning. *Journal of Medical Education*. 5(2). 47-50.

PENDLEY, B.D., R.L. BRETZ AND NOVAK, J.D. 1994. Concept Map as a Tool to Assess Learning in Chemistry. *Journal of Chemical Education*. 71(1). 9-15.

RAO, MANJULA P. 2004. Effect of Concept Mapping in Science on Science Achievement, Cognitive Skills and Attitude of Students. *Proceedings of the International Conference on Science, Technology and Mathematics Education* (epi STEME-HBCSE). 130-131. Goa. India.

SUSAN, CHIOU AND CHEI, CHANG. 2008. The Effect of Concept Mapping on Students' Learning Achievements and Interests. *Innovations in Education and Teaching International*. 45(4). 375-387.

PROBLEM BASED LEARNING IN BASIC PHYSICS - IV

A.K. Mody

V. E. S. College of Arts, Science and Commerce Sindhi Society Chembur, Mumbai

H.C. Pradhan

HBCSE, TIFR, V. N. Purav Marg, Mankhurd, Mumbai

In this article- fourth in the series of articles we present problems for a problem based learning course from the area of heat, thermodynamics and optics. We present the learning objectives in this area of basic physics and what each problem tries to achieve with its solution.

In this article, fourth in the series of Problem Based Learning in Basic Physics, we present problems on heat, thermodynamics and optics. Methodology and philosophy of selecting these problems are already discussed. (Pradhan 2009, Mody 2011)

To review methodology in brief, we note here that this PBL (Problem Based Learning) starts after students have been introduced to formal structure of Physics. Ideally students would attempt only main problem. If they find it difficult, then depending upon their area of difficulty, right auxiliary problem have to be introduced by teacher who is expected to be a constructivist facilitator. Teacher may choose as per her/his requirement or may construct questions on the spot to guide student to right idea and method.

H: Heat and thermodynamics

Learning Objectives

1. To become familiar with heat as a form of energy [that due to random motion].

2. To understand effect of heat on physical properties.
3. Effect of heat on parameters like pressure, temperature etc.
4. Transfer of heat in different processes especially conduction and radiation.
5. Black body radiation and temperature.
6. To understand mathematical structure dealing with above mentioned points.

Problems

1. A narrow necked vessel contains 6 gm of a gas at 7°C and at a certain pressure. The vessel is heated to 147°C , when some of the gas escapes. The pressure of the gas in the vessel is constant. What mass of the gas has escaped? *

Tasks involved in this problem are:

- (a) To apply $PV = nRT$ before and after.
 - (b) Finding out n in the final state and hence how much gas escapes.
2. An air bubble starts rising from the bottom of a lake, 2.5 metres deep. Its diameter increases from 3.6 mm at the bottom to 4 mm at the surface. If the temperature of water on the surface is 40°C , what is the temperature at the

bottom of the lake? [Atmospheric pressure = 0.76 m of Hg; $r_{\text{Hg}} = 13600 \text{ kg/m}^3$; $r_{\text{water}} = 1000 \text{ kg/m}^3$; $g = 9.8 \text{ m/s}^2$] [Mistry]

Tasks involved in this problem are:

(a) Use of $PV = nRT$ knowing that 'n' remains constant.

(b) Using $P = P_{\text{atm}} + h\bar{n}g$

3. A closed vessel contains liquid water in equilibrium with its vapour at 100°C and 1 atm. One gram of water vapour at this temperature and pressure occupies a volume of 1670 cm^3 . The heat of vaporisation at this temperature is 2250 J/gm . (a) How many molecules are there per cm^3 of vapour. (b) How many vapour molecules strike each cm^2 of liquid surface per second? (c) If each molecule which strikes the surface condenses, how many evaporate from each cm^2 per second? (d) Compare the mean kinetic energy of a vapour molecule with the energy required to transfer one molecule from the liquid to the vapour phase.*

Tasks involved in this problem are:

- (a) To visualise what happens at molecular level.
 (b) To use proportionality and mole concept to find number of molecules.
 (c) To use statistical average to estimate number of molecules striking unit area of the liquid surface per second.
 (d) To use energy conservation principles to find number of molecules evaporating.

4. According to Stefan's Law of radiation, a black body with surface temperature T radiates energy σT^4 from its unit surface area every second, where $\sigma = 5.67 \times 10^{-8} \text{ W/m}^2\text{K}^4$ is known

as Stefan's constant. If the earth is in radiative equilibrium with the sun and the average temperature of the earth's surface is 300K , estimate the surface temperature of the sun. Take radius of the sun is $7 \times 10^8 \text{ m}$ and the mean distance between the earth and that of the sun is $1.5 \times 10^{11} \text{ m}$.

Tasks involved in this problem are:

- (a) To estimate energy radiated by sun and fraction of it that is received by the earth.
 (b) Energy that is radiated by the earth.
 (c) If earth is in radiative equilibrium quantity in (1) and (2) should be equal which would allow estimation of Sun's surface temperature.
 (d) The compression ratio (V_1/V_2) of a four stroke internal combustion engine is equal to 9.5. The engine takes in air and gas fuel at temperature 27°C and pressure of 1 atm. The volume is then compressed adiabatically from state 1 to state 2.
 5. The fuel mixture is ignited causing an explosion, which doubles the pressure (state 2 to 3), thus moving the piston into a position in state 3. From state 3 to 4 the gaseous mixture again expands adiabatically until the volume becomes $9.5V$ as shown in PV-diagram and the exhausting valve in the cylinder opens up allowing the pressure in the cylinder to return to 1 atm. ($\bar{\alpha} = \frac{C_p}{C_v} = 1.4$) Determine
 (i) The pressure and temperature of the gaseous mixture in states 1, 2, 3, and 4 respectively.
 (ii) The thermal efficiency of the cycle. [IPhO 1976]

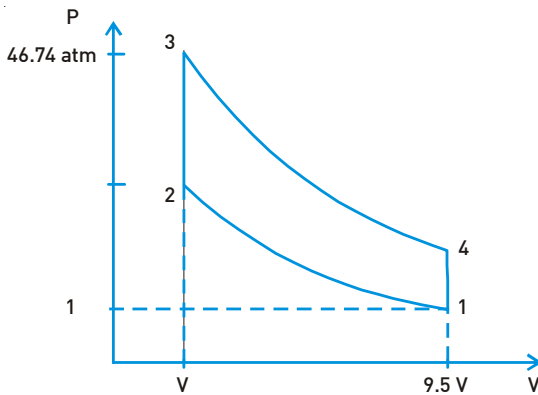

An illustrative problem that deals with thermodynamic processes (isochoric and adiabatic).

Tasks involved in this problem are:

- To start with initial conditions identifying the processes involved and equations governing them.
- To find needed quantities from given information.
- To calculate pressure and temperature at various stages of the cycle using gas equations.
- To calculate energies involved in different processes to calculate efficiency of a cycle.

Surface Tension

- Surface tension is exhibited by liquids due to force of attraction between molecules of the liquid. The surface tension decreases with increase in temperature and vanishes at boiling point. Given that the latent heat of vaporization for water $L_v = 540 \text{ kcal/kg}$, the mechanical equivalent of heat $J = 4.2 \text{ J/Cal}$, density of water $\bar{n}_w = 10^3 \text{ kg l}^{-1}$, Avogadro's No $N_A = 6.0 \times 10^{23} \text{ k mol}^{-1}$ and the molecular weight of

water $M_A = 18 \text{ kg}$ for 1 k mole.

- Estimate the energy required for one molecule of water to evaporate.
- Show that the intermolecular distance for water is $d = \left(\frac{M_A}{N_A} \times \frac{1}{\rho_w} \right)^{1/3}$ and find its value.
- 1 g of water in the vapour state at 1 atm occupies 1601 cm^3 . Estimate the intermolecular distance at boiling point, in the vapour state.
- During vaporisation a molecule overcomes a force F , assumed constant, to go from an intermolecular distance d to d' . Estimate the value of F .
- Calculate F/d , which is a measure of the surface tension. [NCERT EP XI]

The tasks in this problem are already listed as (a), (b),... self explanatory. The aim is to construct conceptual understanding through simple calculation.

I : Optics

Learning Objectives

- To understand formation of image, its nature and position due to mirrors, due to surfaces (plane and curved) separating two media.
- To understand formation of image, its nature and position due to multiple surfaces and lenses.
- To understand wave propagation and superposition based on wave nature and path (or phase) difference.
- To understand mathematical structure dealing with above mentioned points.

Problems

- Find the height of the shortest plane mirror (held vertically) in which a man six feet tall could see his entire image. At what height above the ground should this mirror be placed in order that the man could see his entire image?*

Tasks involved in this problem are:

- Drawing ray diagram to see how image is formed in the mirror.
 - Geometrically establishing relationship between size of the object and minimum size of the mirror needed.
- Screen S is illuminated by two point sources A and B. Another source C sends parallel beam of light towards P on the screen (see Fig.) Line AP is normal to the screen and the lines AP, BP, and CP are in one plane. The distances AP, BP, and CP are 3 m, 1.5 m and 1.5 m respectively. The radiant powers of the sources A and B are 90 W and 180 W respectively. The beam C is of intensity 20 W/m^2 . Calculate the intensity at P on the screen. . [JEE 82]

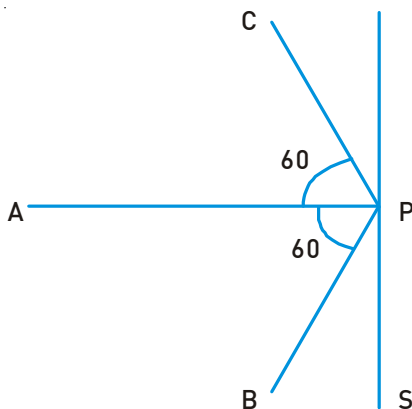

Tasks involved in this problem are:

- To recognise difference between point source and a parallel beam of light.
 - To learn the variation in intensity as light travels distance from different type of sources.
 - To learn how intensity is related to angle of incidence. This had to be discussed with them.
- A person looking through a telescope T just sees the point A on the rim at the bottom of a cylindrical vessel when the vessel is empty (see Fig.). When the vessel is completely filled with a liquid ($n = 1.5$), he observes a mark at the centre B, of the bottom without moving the telescope or the vessel. What is the height of the vessel if the diameter of its cross-section is 10 cm?

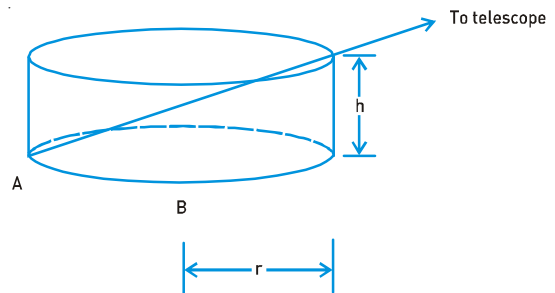

Tasks involved in this problem are:

- Identifying incident and refracted rays.
 - Working out angles for each of the rays.
 - Application of Snell's law of refraction.
- An object is placed 21 cm in front of a concave mirror of radius of curvature 10 cm. A glass slab of thickness 3 cm and refractive index 1.5 is then placed close to the mirror in the space between the object and the mirror. Find the

position of the final image formed. (You may take the distance of the nearer surface of the slab from the mirror to be 1.0 cm) [JEE 80]

Tasks involved in this problem are:

- (a) To draw rays as per the rules of geometrical optics first due to glass slab.
- (b) To treat image formed by one as the object for the next and continue.
- (c) To locate image by mathematical calculation.

11. The Young's double slit experiment is done in a medium of refractive index $4/3$. A light of 600 nm wavelength is falling on the slits having 0.45 mm separation. The lower slit S_2 is covered by a thin glass sheet of thickness 10.4 mm and refractive index 1.5 . The interference pattern is observed on a screen placed 1.5 m from the slit as shown in Fig. P(5) Find the location of the central maximum (bright fringe with zero path difference) on the y -axis. (b) Find the light intensity at point O relative to the maximum fringe intensity. (c) Now, if 600 nm light is replaced by white light of range 400 to 700 nm , find the wavelengths of light that form maxima exactly at point O. [All wavelengths in this problem are for the given medium of refractive index $4/3$. Ignore dispersion] [JEE 99]

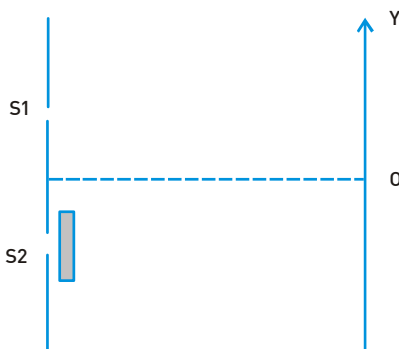

Tasks involved in this problem are:

- (a) To find the additional path difference introduced by the glass plate.
- (b) To locate the point on the screen where path difference will be zero knowing the fringe width.
- (c) To estimate the variation in intensity on the screen from consideration of path difference.

Solutions

1. Gas Law

Gas Law: $PV = nRT$: For the gas inside the vessel V and P are constants.

$\therefore nT = \text{constant}$ or $nM_A T = \text{constant} \Rightarrow mT = \text{constant}$ where m is mass of the gas and T its absolute temperature.

$m_1 = 6\text{ gm}$ at $T_1 = 7^\circ\text{C} = 280\text{ K}$

and $m_2 = ?$ to be found at $T_2 = 147^\circ\text{C} = 420\text{ K}$

$$\therefore m_2 = m_1 (T_1/T_2) = 4\text{ gm}$$

$$\therefore \Delta m = m_1 - m_2 = 2\text{ gm} : \text{mass of the gas escaped.}$$

2. Gas Law

$pV = nRT$ and $\frac{pV}{T} = nR = \text{constant}$ for a given bubble

$P_{\text{depth}} = P_{\text{surface}} + h\rho g$ where ρ is the density of water.

$$\therefore T_1 = T_2 \frac{P_1 V_1}{P_2 V_2} = T_2 \left(\frac{P_1}{P_2}\right) \left(\frac{d_1}{d_2}\right)^3 \text{ and } P_1 = P_2 + h\rho g$$

$$T_1 = 283.4\text{ K} = 10.4^\circ\text{C}$$

3. Kinetic Theory

- (a) Number of molecules $N = n N_A$
where n is number of moles and N_A is

Avogadro Number.

$$\therefore \frac{N}{V} = \left(\frac{P}{RT}\right) N_A = 2 \times 10^{19} \text{ per cm}^3$$

(b) $N/3$ strike wall area l^2 in time $2l/c$ where

$$c = \sqrt{\frac{3RT}{M_A}}$$

$$\therefore \frac{1}{6} \frac{N}{l^3} c = 2.4 \times 10^{23} \text{ per cm}^2 \text{ per sec}$$

(c) Energy delivered

$$\text{per cm}^2 \text{ per sec} = \frac{1}{6} \frac{N}{l^3} c \times \frac{3}{2} kT = 1860.8 \text{ J}$$

$U/N = 6.7210^{-20}$ J/molecule needed for evaporation.

$$\text{Thus } \frac{\frac{1}{6} \frac{N}{l^3} c \times \frac{3}{2} kT}{\frac{U}{N}} = 5.279 \times 10^{16} \text{ gets evaporated every sec from } 1 \text{ cm}^2.$$

(d) Mean K.E. of vapour molecules = $(3/2)kT = 7.72 \times 10^{-21}$ J

Each vaporizing molecule needs energy = 6.72×10^{-20} J

4. Radiation

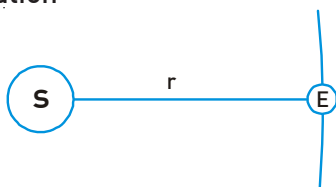

Sun radiates energy sT_s^4 every second. Earth obstructs effectively what is flowing through area πR_E^2 out of $4\pi r^2$. If Earth's temperature is T_E it radiates $4\pi R_E^2 s T_E^4$ every second.

\therefore In radiative equilibrium:

$$\sigma T_s^4 \frac{\pi R_E^2}{4\pi r^2} = 4\pi R_E^2 \sigma T_E^4 \Rightarrow T_s = T_E \left(\frac{4r^2}{R_E^2}\right)^{1/4} = 6210.6 \text{ K}$$

5. Thermodynamic Cycle

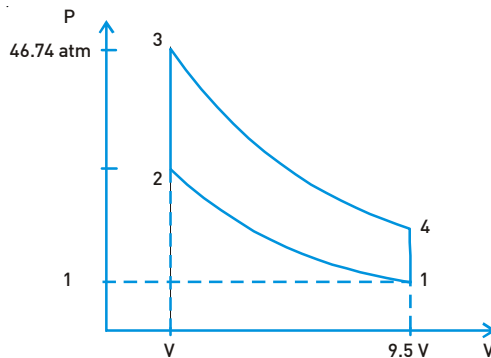

Given: $P_1 = 1 \text{ atm}$, $T_1 = 300 \text{ K}$, and $V_1/V_2 = 9.5$

(i) Path 1→2 : adiabatic :

$$P_2 = P_1 \left(\frac{V_1}{V_2}\right)^\gamma = 23.38 \text{ atm} \quad T_2 = T_1 \frac{PV_2}{PV_1} = 738.3 \text{ K}$$

Path 2→3 : isochoric ($V_3 = V_2$): $P_3 = 2P_2 = 46.74 \text{ atm}$

$$T_3 = 2T_2 = 1476.5 \text{ K}$$

Path 3→4 : adiabatic : $V_4/V_3 = 9.5$ and

$$P_4 = P_3 \left(\frac{V_3}{V_4}\right)^\gamma = 46.74 \times \left(\frac{1}{9.5}\right) = 2.0 \text{ atm}$$

$$T_4 = T_3 \frac{PV_4}{PV_3} = 600 \text{ K}$$

(ii) Heat intake = $C_v(T_3 - T_2) = (3/2)R(738.24) = 1107.4 R$

$$\text{Heat Exhaust} = C_v(T_4 - T_1) = (3/2)R(300) = 450 R$$

$$\text{Work done} = (1107.4 - 450) R = 657.4 R$$

$$\therefore \text{Efficiency } \eta = (W/\text{Heat intake}) = 0.594 \text{ @ } 59.4\%$$

6. Surface Tension

(a) If L_v is the energy required for unit mass of the substance to evaporate, M_A and N_A are molecular weight and Avogadro Number respectively then energy needed for one molecule to evaporate is

$$u = \frac{M_A}{L_v N_A} = 6.8 \times 10^{-20} J$$

- (b) If density of liquid is \tilde{n}_w , then volume occupied by a molecule is where $d^3 = \frac{M_A}{\rho_w N_A}$ d is inter molecular distance. This gives $d = 3.1 \times 10^{-10} m$
- (c) In vapour state this distance increases by a factor of $(1601)^{1/3} = 11.89$ i.e. new inter molecular distance becomes $d' = 36.3 \times 10^{-10} m$.
- (d) Thus if intermolecular force per unit distance is F then work done in overcoming it for evaporation is $F(d' - d) = u$. This gives $F = 0.2048 \times 10^{-10} N$

- (e) Thus $\frac{F}{d} = 6.6 \times 10^{-2} N/m^2$ is the measure of surface tension of the water.

7. Reflection on a Plane Surface

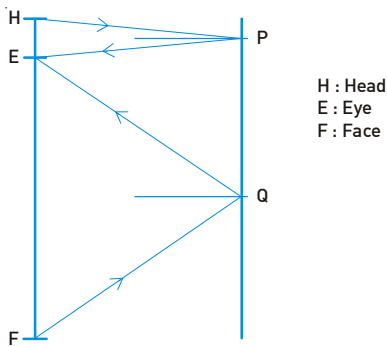

Referring to Geometry and laws of reflection:
 $PQ = (1/2) (HE + EF)$
 $= (1/2) (HF)$
 $= (1/2)$ of height of the person

8. Photometry

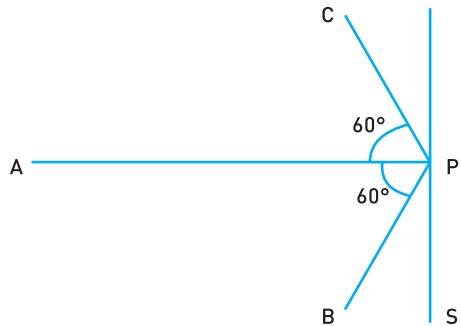

A is a point source, and light is incident normally on screen at P:

which gives $I_{P,A} = E_A / d_{PA}^2 = 10 / 4\pi \text{ W/m}^2$

B is a point source, and light is incident at an angle on screen at P: which gives

$$I_{P,B} = (E_B / 4\pi d_{PB}^2) \cos 60^\circ = 40 / 4\pi \text{ W/m}^2$$

C sends a parallel beam at P but at an angle

which gives $I_{P,C} = I_C \cos 60^\circ = 10 \text{ W/m}^2$

$$I_P = I_{P,A} + I_{P,B} + I_{P,C} = 12.5 / \pi + 10 \approx 14 \text{ W/m}^2$$

9. Refraction at a Plane Surface

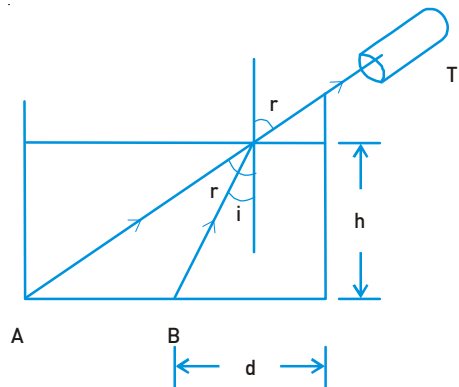

$$\frac{\sin i}{\sin r} = \frac{1}{\mu}, \quad \sin i = \frac{d}{\sqrt{h^2 + d^2}} \text{ and } \sin r = \frac{2d}{\sqrt{h^2 + 4d^2}}$$

Solving which we get $h = d \sqrt{\frac{4\mu^2 - 4}{4 - \mu^2}} = 8.45 \text{ cm}$

10. Refraction and Reflection at a Curved Surface

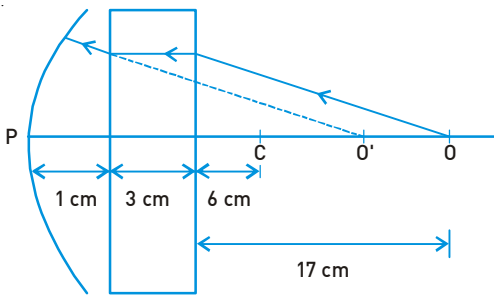

As seen from the mirror, if object is at O, it appears to be at O'. The displacement can be given by $OO' = t(1 - 1/\mu) = 1 \text{ cm}$ [* This is proved as given at the end]

$$\Rightarrow PO' = PO - OO' = 20 \text{ cm}$$

For mirror $f = R/2 = 5 \text{ cm}$ and $u = 20 \text{ cm}$ and using $\Rightarrow v = Pl' = 20/3 \text{ cm}$

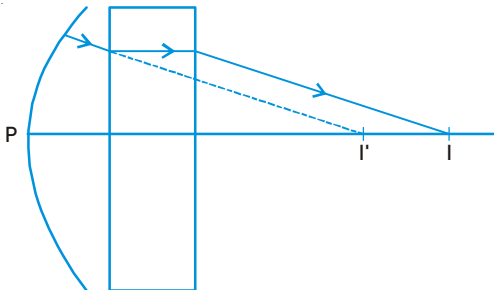

and $II' = t(1 - 1/\mu) = 1 \text{ cm}$ as above which gives $PI = 23/3 \text{ cm} = 7.67 \text{ cm}$ from the mirror.

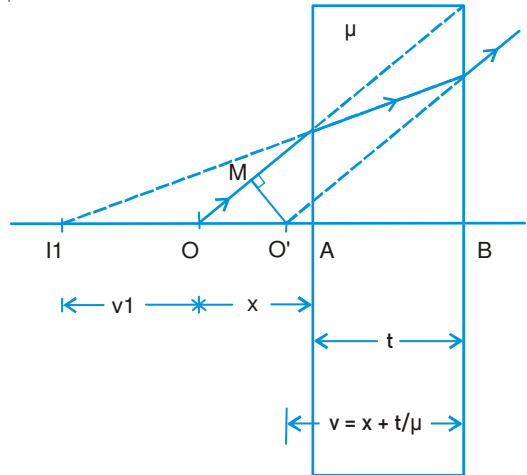

For a curved surface separating two media

$$\frac{\mu_2}{v} - \frac{\mu_1}{u} = \frac{\mu_2 - \mu_1}{R}$$

here $R = \infty$ for both the surfaces

$$\therefore \text{For 1st surface} \quad v_1 = -\mu x$$

$$\therefore \text{For 2nd surface} \quad u = -(\mu x + t)$$

$$\therefore \frac{1}{v} + \frac{\mu}{\mu x + t} = 0 \Rightarrow v = -(x + t/\mu)$$

$$\therefore OO' = OB - O'B = (x + t) - (x + t/\mu) = t(1 - 1/\mu) = 1 \text{ cm}$$

11. Young's Double Slit Interference

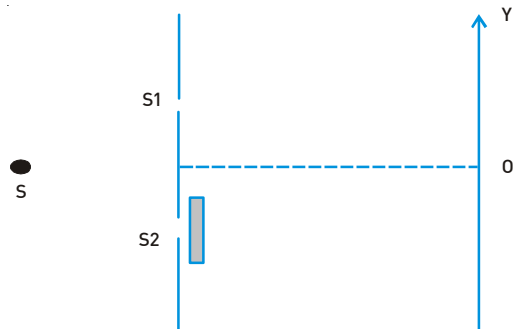

All wavelengths here corresponds to $m = 4/3$

(a) Fringe width $\Delta x = \lambda D/d = 2 \text{ mm}$

$$t(\mu - 1) = n\lambda \text{ and } \mu = \frac{\mu_r}{\mu_g} = 9/8$$

$$\therefore n = t(\mu - 1/\lambda) = \quad : \text{ no of fringes}$$

$$\therefore \text{Shift } y = n\Delta x = 2 =$$

(b) $\Delta x = \lambda/6 + 2\lambda \Rightarrow$ Phase shift $a = 2p\Delta x/l = \pi/3$: acute angle

$$\therefore I_o = 4A^2 \text{ and } I = A^2(1 + \cos\alpha)^2 = (9/4)A^2 = (9/16)I_o$$

$$(c) n = t(\mu - 1/\lambda) : \text{integer} : n = \frac{1.3 \times 10^{-6}}{\lambda} = \frac{1300}{\lambda}$$

for λ in nm.

$$\therefore n = 2 \Rightarrow \lambda = 650 \text{ nm}$$

and $n = 3 \Rightarrow \lambda = 433.3 \text{ nm}$ in given range.

References

IPhO — International Physics Olympiad.

JEE — Joint Entrance Examination for Admission to IIT.

MISTRY, N. M. 1999. *Concepts of Physics for Class XI*. Uttam Prakashan, Mumbai.

MODY A. K. AND H. C. PRADHAN. 'Problem Based Learning in Basic Physics – I. *School Science*. 49 (3). September 2011.

NCERT. 2006. *Physics Textbook for Class XI part-I*. New Delhi.

_____. 2009. *PHYSICS EXEMPLAR PROBLEMS*. Class XI. New Delhi.

PRADHAN, H.C. AND A. K. MODY. 2009. '*Constructivism Applied to Physics Teaching for Capacity Building of Undergraduate Students*'. *University News*. 47 (21) 4-10.

RUBRICS TO REFINE TEACHING SKILLS IN MATHEMATICS AT THE SECONDARY STAGE

P.K. Chaurasia

Associate Professor
RIE, Ajmer
email: praveencl@gmail.com

Assessment for learning is the process of seeking and interpreting evidence for use by learners and their teachers to decide where the learners are in their learning, where they need to go and how best to get there. Assessment in education refers to any of the many ways in which someone seeks to gain evidence to help them to measure or to make judgements about the quality, quantity or level of a pupil's learning. The emphasis in assessment for learning is on the active engagement of pupils with assessment as an integral component of the learning process. When we think of the learner as an active participant in constructing his or her own conceptualisation of mathematics, we need to come up with an assessment strategy through which we could assess the progress of learner in different dimensions of the concepts. Rubrics divide an assignment into its component parts and provide a detailed description of what constitutes acceptable or unacceptable levels of performance for each of those parts. Keeping copies of individual learners' rubrics can allow us to pinpoint a learner's continuing improvement or weaknesses over time, rubrics showing learner development over time can also allow us to gain a clearer view of teaching blind spots, omissions, and strengths.

In this paper, a detail about different parts of rubrics has been described. Sufficient number of mathematical illustration has also been provided. It can be a utility tool for teachers to refine their teaching skills in respect of their learners.

Introduction

In the focus paper of Teaching of Mathematics, NCERT (2005), it has mentioned that with Mathematics students learn to represent quantitative and spatial relationships in a broad range of situations. They can express these relations by using terms, signs, and symbols of mathematics. They learn to use procedures with the signs and symbols, follow rules, carry out numerical and symbolic calculations and make predictions and interpret results based on the use of the procedures. They come to understand the importance for and use of mathematical terms, signs, symbols and process for solving

interdisciplinary problems. The sequence of contextual activities permits students to gradually develop methods for symbolising problem situations. It is also mentioned that instruction in classrooms should not begin by presenting students with the formal terms, signs, symbols, and rules, along with the expectation that students then will appropriately use these formal ideas to solve problems. It has been recommended that classroom leads students to value and understand the need for mathematics through the gradual development of their ability to mathematically represent complex problems, a process called "progressive formalisation."

The textbooks developed on the basis of these recommendations include tasks and questions designed to engage students in mathematical thinking and discourse. Students explore mathematical relationships, develop their own strategies for solving problems, use appropriate problem-solving tools, work together cooperatively, and value one another's strategies. Students are encouraged to explain their thinking as well as their solutions. Teachers are expected to help students develop common understanding and usage of the terms, signs, symbols, and rules of mathematics, which the students then attempt to use in articulating their thinking. Other activities have been designed so that students can extend their ideas to new problem situations.

The monitoring of students' progress has always been a key aspect of the job of teaching. Mathematics teachers traditionally have monitored progress by giving quizzes and chapter tests, scoring and counting the number of correct answers on each, and periodically summarising student performance in terms of a letter grade. The need to consider alternative ways of assessing students' classroom performance grew as a consequence of teachers' role as recommended by NCF-2005.

Continuous and Comprehensive Evaluation (CCE)

We need to emphasis on the word "Educational Evaluation" first. What we understand that evaluation is an activity which is conducted by the educators/ teachers in order to continuously and systematically review and then enhance the teaching learning process that they are endeavouring to facilitate. Educational evaluation

deals with student's evaluation which includes the assessment of the performance of the students in the areas of their personality development in terms of intellectual, social and emotional development after they have been provided learning experiences through classroom practices.

Evaluation is often confused with the term measurement and both the terms are used synonymously. But both are not the same. The term measurement stands for measuring the performance of the student on a particular scale. The pattern of measurement which is mostly followed in our assessment system relates to marking on a scale of 0-100 marks. This also includes pass-fail system where in all those who secure 33 per cent marks and above are declared pass and below this are tagged fail. This scale is a matter for classifying the students on the basis of the marks they obtain in a test or examination. Therefore, measurement provides a quantitative description of pupils' performance based on artificial classification. It does not include value judgment and thus, it gives a fragmented picture of student's performance. Moreover, all these aspects are related only to intellectual growth.

On the other hand evaluation is broader term as compared to measurement and it includes both quantitative and qualitative description of the performance and value judgment. Regarding quantitative description as written above, measurement on a scale is applied and marks are allotted. For qualitative description interpretation of the marks secured by the student are made in reference to him/herself, her/his group and certain criteria. It also includes value judgment regarding the desirability of

behaviour related to all the domains of personality development.

Evaluation is an integral part of any teaching and learning programme. Whenever a question is asked in a class and answered by a student and the answer is judged by the teacher, evaluation takes place. Thus, both teaching and evaluation go hand in hand with each other. In fact, it is not possible to have teaching and learning without evaluation.

Both teaching and evaluation are based on the instructional objectives which provide direction to them. Instructional objectives are those desirable behaviour which are to be developed in students through the learning experiences. These are reflected in the form of syllabus, instructional material and information given by the teacher. Instructions are given for achieving the objectives and evaluation is done to see whether the instructional objectives have been achieved and to what extent. The interrelationship of objectives, instructional process or the learning experiences and evaluation in a programme of teaching can be expressed more clearly as shown in Fig. 1

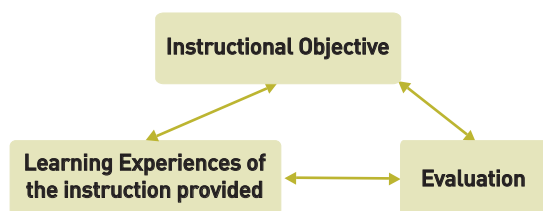

Fig. 1

Fig. 1 illustrates that the three components teaching, learning and evaluation constitute an integrated network in which each components depends on the other. Thus, through evaluation, the teacher not only assesses as to how far the

student has achieved the objectives but also examines the effectiveness of the teaching strategy such as methodologies, means and the materials used for achieving those objectives.

The first step in this change process involves to motivate teachers to see the need to change their assessment practices. This usually comes as a consequence of changing their instructional practices and seeing the quality of the work their students are doing. For this purpose, rubrics may be introduced for the process evaluation of concepts and it may be an effective tool towards continuous and comprehensive evaluation.

Introducing Rubrics

At its most basic, a rubric is a scoring tool that lays out the specific expectations for an assignment. Rubrics divide an assignment into its component parts and provide a detailed description of what constitutes acceptable or unacceptable levels of performance for each of those parts. Rubrics can be used for grading a large variety of assignments and tasks: Project evaluation, discussion participation, laboratory reports, portfolios, group work, oral presentations, and more.

Do we need a rubric?

How do we know that we need a rubric? One sure sign is if we check off more than three items from the following list:

- We are getting pain from writing the same comments on almost every student paper.
- We're far behind in our grading.
- Students often complain that they cannot read the notes we labored so long to produce.

- We have graded all our papers and worry that the last ones were graded slightly differently from the first ones.
- We want students to complete a complex assignment that integrates all the work over the term and are not sure how to communicate all the varied expectations easily and clearly.
- We want students to develop the ability to reflect on ill-structured problems but we aren't sure how to clearly communicate that to them.
- We give a carefully planned assignment that we never used before and to our surprise, it takes the whole class period to explain it to students.
- We give a long narrative description of the assignment in the syllabus, but the students continually ask two to three questions per class about our expectations.
- We have worked very hard to explain the complex end-of-term paper; yet students are starting to regard us as incomprehensible assignments.

Rubrics set you on the path to addressing these concerns.

What are the parts of a rubric?

Rubrics are composed of four basic parts in which the teacher sets out the parameters of the assignment. The parties and processes involved in making a rubric can and should vary tremendously, but the basic format remains the same. In its simplest form, the rubric includes a task description (the assignment), a scale of some sort (levels of achievement, possibly in the form of grades), the dimensions of the assignment (a breakdown of the skills/knowledge involved in the assignment), and descriptions of what constitutes each level of performance (specific feedback) all set out on a grid, as shown in Fig. 2.

	Scale level 1	Scale level 2	Scale level 3
Dimension 1			
Dimension 2			
Dimension 3			
Dimension 4			

Fig 2 : Basic rubric grid format

- We work with our colleagues and collaborate on designing the same assignments for program courses, yet we wonder if our grading scales are different.
 - We've sometimes been disappointed by whole assignments because all or most of the class turned out to be unaware of academic expectations.
- This is the most common, but sometimes we may use more. Rarely, however, we may go over our maximum of five scale levels and six to seven dimensions. We look at the four component parts of the rubric and, using an assignment as an example, provide the above grid *part-by-part* until it is a useful grading tool (a usable rubric) for the teacher and a clear indication of expectations and actual performance for the student.

Part-by-Part Development of a Rubric

Part 1: Task Description

The task description is almost always originally framed by the teacher and involves a “performance” of some sort by the student. The task can take the form of a specific assignment, such as a paper, a poster, or a presentation.

difficult it becomes to differentiate between them and to articulate precisely why one student’s work falls into the scale level it does. On the other hand, more specific levels make the task clearer for the student and they reduce the teacher’s time needed to furnish detailed grading notes. We have the following grid (Fig. 3) for scaling in rubrics in Mathematics at the secondary stage.

Dimensions	Exemplary	Competent	Developing
Knowledge/Understanding			
Geometrical Skills			
Analytical Skills			
Applications			

Fig.3 : Part 2: Scales

Part 2: Scale

The scale describes how well or poorly any given task has been performed and occupies yet another side of the grid to complete the rubric’s evaluative goal. Terms used to describe the level of performance should be tactful but clear. Here are some commonly used labels compiled:

- Sophisticated, competent, partly competent, not yet competent
- Exemplary, proficient, marginal, unacceptable
- Advanced, intermediate high, intermediate, novice
- Distinguished, proficient, intermediate, novice
- Accomplished, average, developing, beginning.

There is no set formula for the number of levels a rubric scale should have. We should prefer to clearly describe the performances at three levels using a scale. The more levels there are, the more

Part 3: Dimensions

The dimensions of a rubric lay out the parts of the task simply and completely. A rubric can also clarify for students how their task can be broken down into components and which of those components are most important. Is it calculation? The analysis? The factual content? The process techniques? And how much weight is given to each of these aspects of the assignment? Although it is not necessary to weight the different dimensions differently, adding points or percentages to each dimension further emphasises the relative importance of each aspect of the task. Dimensions should actually represent the type of component skills students must combine in a successful scholarly work, such as the need for a firm grasp of content, technique, citation, examples, analysis, and a use of language appropriate to the occasion. When well done, the dimensions of a rubric (usually listed along one

side of the rubric- Fig. 3) will not only outline these component skills, but after the work is graded, should provide a quick overview of the student's strengths and weaknesses in each dimension.

Breaking up the assignment into its distinct dimensions leads to a kind of task analysis with the components of the task clearly identified. Both students and teachers find this useful. It tells the student much more than a mere task assignment or a grade reflecting only the finished product. Together with good descriptions, the dimensions of a rubric provide detailed feedback on specific parts of the assignment and how well or poorly those were carried out.

Part 4: Description of the Dimensions

Dimensions alone are all-encompassing categories, so for each of the dimensions, a rubric should also contain at the very least a description of the highest level of performance in that dimension. A rubric that contains only the description of the highest level of performance is called a scoring guide rubric. Scoring guide rubrics allow for greater flexibility and the

personal touch, but the need to explain in writing where the student has failed to meet the highest levels of performance does increase the time it takes to grade using scoring guide rubrics.

As per the secondary stage mathematics syllabus, we have selected 7 themes:

1. Geometry
2. Trigonometry
3. Number system
4. Algebra
5. Statistics
6. Coordinate Geometry
7. Mensuration

In this article, as per the syllabus of Secondary Mathematics we have listed tasks for the theme Geometry and rubrics for the several task in the following:

- **Basic Concepts-1**

1. Task: To check whether the student has understood the basic terminology (Point , Line , Plane etc.) of Geometry

Dimensions — Knowledge/Understanding

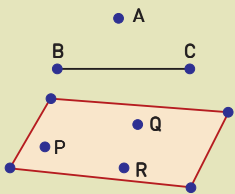
Exemplary	Competent	Developing
<ul style="list-style-type: none"> • The student understands the meaning of the word Geometry. S/he is able to recognise and draw the basic building blocks of geometry viz., point, line and plane and knows that they are undefined terms. • S/he is able recognise the geometrical shapes in his surroundings. • S/he is also able to define, recognise and draw terms like collinear points, coplanar points, line 	<ul style="list-style-type: none"> • The student understands the meaning of the word Geometry. S/he does not know that the basic building blocks of Geometry viz., point, line and plane are undefined. S/he is able to draw basic building blocks. • S/he is able to recognise the geometrical shapes in his surroundings. 	<ul style="list-style-type: none"> • The student understands the meaning of the word Geometry. • S/he is not able to recognise the geometrical shapes in his surroundings. • S/he is able to draw points , lines etc.

<p>segment , ray , intersecting lines , parallel lines ,concurrent lines etc.</p> <p>S/he is able to solve the following question successfully.</p> <p>Q.1. Draw and label each of the following:</p> <p>(a) a segment with endpoints U and V</p> <p>(b) opposite rays with a common end point Q</p>	<ul style="list-style-type: none"> S/he is not able to define terms like collinear points, coplanar points, line segment, ray, intersecting lines, parallel lines, concurrent lines etc. but he is able to draw them. S/he is able to solve the question. 	<p>but not able to draw intersecting lines, parallel lines, concurrent lines etc.</p> <ul style="list-style-type: none"> S/he is able to solve the question but not able to label the figures correctly.
--	---	---

Dimensions — Analytical Skill

Exemplary	Competent	Developing
<ul style="list-style-type: none"> The student applies her/his problem solving skills to solve the following question successfully : <p>Q. Use the figure to name each of the following :</p> <p>(a) Three points</p> <p>(b) Two lines</p> <p>(c) Two planes</p> <p>(d) One ray</p> <p>(e) Intersecting lines</p> <p>The student understands the meaning of the following statement :</p> <p>If two rays share a common end point , then they form a line.</p>	<ul style="list-style-type: none"> The student is able to recognise and name points and lines but unable to recognise plane, ray and intersecting lines. 	<ul style="list-style-type: none"> The student is able to recognise points and line but not able to name them.

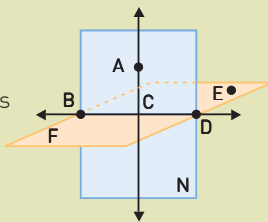



Dimensions — Application

Exemplary	Competent	Developing
<ul style="list-style-type: none"> The student is able to recognise a sheet of paper as a plane. S/he is able to draw a line segment by paper folding. S/he is also able to locate a point as the intersection of two line segments by paper folding. 	<ul style="list-style-type: none"> The student is able to recognise a sheet of paper as a plane. He is not able to draw line segment and point using paper folding. 	<ul style="list-style-type: none"> The student is not able to understand paper folding activities.

• **Basic Concepts- 2**

1. Task: To check whether the student has understood the concepts of angles and its types.

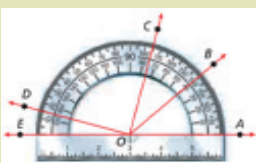
Dimensions — Knowledge/Understanding

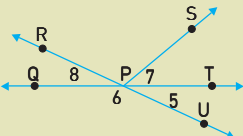
Exemplary	Competent	Developing
<ul style="list-style-type: none"> The student understands the definition, naming conventions, interior and exterior of an angle. <p>Student is able to answer the following question correctly.</p> <p>Q.1 A surveyor recorded the angles formed at a point T and three distant points Q, R and S.</p>  <p>Name the three angles</p> <ul style="list-style-type: none"> The student knows how to measure an angle in degrees using a protractor. <p>The student is able to answer the following question correctly.</p> <p>Q.2. Find the measure of angle formed by rays OA and OB and OA and OE.</p>  <ul style="list-style-type: none"> Student is able to add two given angles. The student is able to define, recognise and draw acute angles, right angle, obtuse angle, straight angle, reflex angle, complete angle and zero angle. <p>Student is able to solve the following question successfully</p> <p>Q.3. Identify right angle , acute angle , obtuse angle and straight angle in the following Figures :</p>  <ul style="list-style-type: none"> The student is able to define, recognise and draw various pairs of angles viz; adjacent angles, complementary angles, supplementary angles, vertically opposite angles and linear pair. <p>The student is able to solve the following question successfully :</p> <p>Q.4. Identify adjacent angles, vertically opposite angle and linear pair of angles in the following Figure :</p> 	<ul style="list-style-type: none"> The student is able to define an angle but he is not able to name angles. He is able to identify interior and exterior of an angle. Student is able to solve Q.1. partially. He is able to identify the angles but not able to name them. The student is able to measure angle in degree using protactor. Student is able to measure angle AOB but unable to measure angle AOE in Q.2. The student is able to add angles. The student is able to define and recognise different types of angles. S/he is not able to draw them. S/he is able to solve Q.3 successfully. The student is able to define and recognise various pairs of angles. He is not able to draw them. Student is able to solve Q.4 successfully. 	<ul style="list-style-type: none"> The student is able to identify the interior and exterior of an angle. He is not able to define and name angles. S/he is not able to solve 1. The student is not able to measure angles using protactor. He is not able to solve Q.2. The student is able to add angles. The student is able to define different types of angles. He is not able to draw and recognise them. He is not able to solve Q.3. The student is able to define various pairs of angles. He is not able to draw and recognise them. He is not able to solve Q.4.

Dimensions — Analytical Skill

Exemplary	Competent	Developing
<ul style="list-style-type: none"> The student has the skill to solve the following question successfully. <p>Q.1. Given "A = 56° and "B = (2x - 4)°, find the measure of each of the following.</p> <p>(a) Supplement of angle A (b) Complement of angle A (c) Supplement of angle B (d) Complement of angle B</p>	<ul style="list-style-type: none"> The student is able to understand Q.1 but he is not able to apply concepts of supplementary angles correctly. 	<ul style="list-style-type: none"> The student understands that measure of two angles are given but he is not able to apply concepts of complementary and supplementary angles.

Dimensions — Application

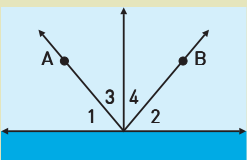
Exemplary	Competent	Developing
<ul style="list-style-type: none"> The student is able to apply the knowledge of angles to solve the following question successfully. <p>Q.1. A sprinkler swings back and forth between A and B in such a way that $\angle 1 = \angle 2$. $\angle 1$ and $\angle 3$ are complementary and $\angle 2$ and $\angle 4$ are complementary. If $\angle 1 = 45^\circ$, find $\angle 2$, $\angle 3$ and $\angle 4$.</p> 	<ul style="list-style-type: none"> The student is not able to apply concept of complementary angles. 	<ul style="list-style-type: none"> The student is not able to understand the question.

Similarly, the reader may develop rubrics for the following task related to Basic concepts of Geometry theme.

• **Basic Concepts- 3**

3. Task: To check whether the student has understood what are curves, polygons, triangles,

quadrilaterals and circles.

• **Lines and Angles - 1**

4. Task: To check whether the student has understood the concept of a transversal and angles formed by a transversal when it intersects two or more parallel or non-parallel lines.

Dimensions — Knowledge/Understanding

Exemplary	Competent	Developing
<ul style="list-style-type: none"> The student understands the meaning of a transversal. He can define, identify and draw a transversal. 	<ul style="list-style-type: none"> The student is able to identify a transversal only when it intersects two parallel lines. He is able to 	<ul style="list-style-type: none"> The student is not able to define a transversal. He is unable to solve Q.1.

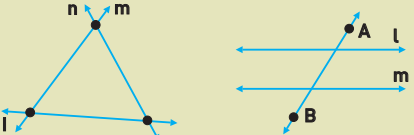
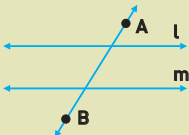
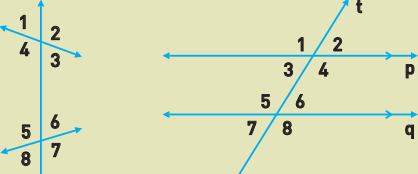
<p>The student is able to solve the following questions successfully :</p> <p>Q.1. Identify transversals in the following figures.</p>  <ul style="list-style-type: none"> • S/he is able to identify the interior and exterior region when transversal intersects parallel/ non-parallel lines. <p>The student is able to solve the following question successfully :</p> <p>Q.2. Identify the interior and exterior region in the following figure</p>  <ul style="list-style-type: none"> • The student is able to identify , name and draw angles formed when a transversal intersects parallel / non-parallel lines. <p>Student is able to solve the following question successfully :</p> <p>Q.3. Identify and name pairs of corresponding, interior alternate angles, exterior alternate angles, co-interior angles in the following figures :</p> 	<p>identify line AB of figure (ii) of Q.1. as transversal.</p> <ul style="list-style-type: none"> • The student is able to identify interior and exterior region when two parallel lines is intersected by a transversal. Student is able to solve Q.2. • The student is able to identify , name and draw angles formed when a transversal intersects parallel lines. He is able to solve part (ii) of Q.3. 	<ul style="list-style-type: none"> • The student is able to identify exterior region only. Student is able to solve Q.2 partially. • The student is not able to solve Q.3.
---	---	--

Dimensions — Analytical Skill

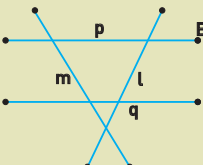
Exemplary	Competent	Developing
<ul style="list-style-type: none"> • The student is able to solve the following question : Identify and mark pairs of corresponding, alternate and co-interior angles in the following Figure 	<ul style="list-style-type: none"> • The student is able to solve Q.1. partially. He understands that there can be only one transversal for one set of parallel lines. 	<ul style="list-style-type: none"> • The student is not able to solve Q.1.

Similarly, the reader may develop rubrics for the following task related to lines and angles of Geometry theme.

• Lines and Angles - 2

5. Task: To check whether the student has understood the concepts of relationship between two corresponding angles, two alternate angles and two co-interior angles when a transversal intersects a pair of parallel lines.

• Triangle - 1

6. Task: To check whether the student has understood the concept of angle sum property of a triangle.

• Triangle - 2

7. Task: To check whether the student has understood the concepts of median, altitude, angle bisector, perpendicular bisector and points of their concurrency.

Dimensions — Knowledge/Understanding

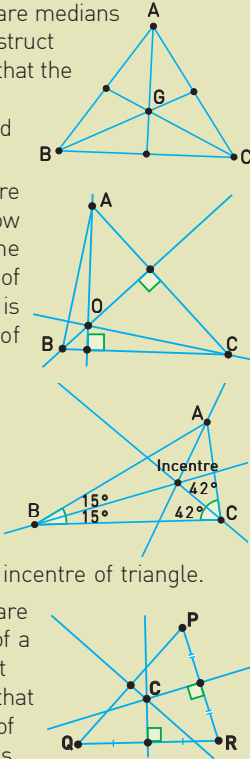
Exemplary	Competent	Developing
<ul style="list-style-type: none"> The student knows what are medians of a triangle, how to construct them and he also knows that the point of concurrency of medians is called centroid (G) of triangle. The student knows what are altitudes of a triangle, how to construct them and he also knows that the point of concurrency of altitudes is called orthocenter (O) of triangle. The student knows what are angle bisectors of a triangle, how to construct them and he also knows that the point of concurrency of angle bisectors is called incentre of triangle. The student knows what are perpendicular bisectors of a triangle, how to construct them and he also knows that the point of concurrency of perpendicular bisectors is called circumcentre (C) of triangle. 	<ul style="list-style-type: none"> The student knows what are medians of a triangle. He knows how to construct them and s/he also knows that the point of concurrency of medians is called centroid of triangle. The student knows what are altitudes of a triangle. He does not know how to construct them. He knows that the point of concurrency of altitudes is called orthocentre of triangle. The student knows what are angle bisectors of a triangle. s/he does not know how to construct them. He knows that the point of concurrency of angle bisectors is called incentre of triangle. The student knows what are perpendicular bisectors of a triangle. S/he does not know how to construct them. He knows that the 	<ul style="list-style-type: none"> The student knows what are medians of a triangle. S/he is not able to construct them and he does not know that the point of concurrency of medians is called centroid of triangle. The student knows what are altitudes of a triangle. S/he is not able to construct them and he does not know that the point of concurrency of altitudes is called orthocentre of triangle. The student knows what are angle bisectors of a triangle. S/he is not able to construct them and he does not know that the point of concurrency of angle bisectors is

- The student knows what are angle bisectors a triangle, how to construct them and the point, where angle bisector of one of the internal angles of a triangle meets with the angle bisectors of the other two exterior angles of the same triangle, is called the ex-centre of the triangle.

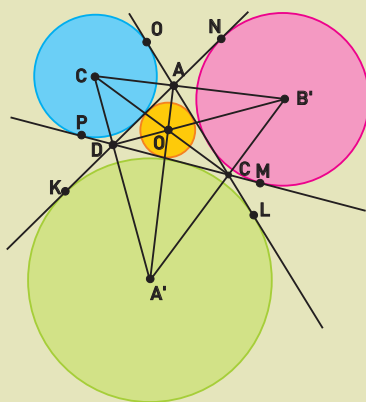

point of concurrency of perpendicular bisectors is called circumcentre of triangle.

- The student knows what are angle bisectors. S/he is not able to construct them. S/he is able to define ex-centre of a triangle.

called incentre of triangle.

- The student knows what are perpendicular bisectors of a triangle. S/he is not able to construct them and he does not know that the point of concurrency of perpendicular bisector is called circumcentre of triangle.
- The student knows what are angle bisectors. S/he is not able to construct them. He is not able to define ex-centre.

Dimensions — Analytical Skill

Exemplary	Competent	Developing
<ul style="list-style-type: none"> • The student understands the property that centroid divides the median in the ratio 2:1 from vertex side. • The student knows that the centroid always lies inside the triangle irrespective of the type of triangle. • The student knows the position of incentre , orthocenter , ex-centre and circumcentre in different types of triangles. 	<ul style="list-style-type: none"> • The student understands the property that centroid divides the median in the ratio 2:1 from vertex side. • The student does not know the position of centroid in different types of triangles. • The student does not knows the position of incentre, orthocenter, ex-centre and circumcentre in different types of triangles. 	<ul style="list-style-type: none"> • The student does not know about the ratio in which it divides the median. He is also unaware of the position of the centroid in different types of triangles. • The student does not knows the position of incentre , orthocenter , ex-centre and circumcentre in different types of triangles.

Similarly, reader may develop rubrics for the following tasks related to Triangle of Geometry theme.

- **Triangle- 3**
- 8. Task:** To check whether the student has understood the inequalities in triangle
- **Triangle - 4**
- 9. Task:** To check whether the student has understood the meaning of congruence and different criteria of congruence viz SSS , SAS , ASA , AAS and RHS.
- **Triangle- 5**

10. Task: To check whether the student is able to understand the concepts of Isosceles and Equilateral Triangles.

- **Triangle- 6**
- 11. Task:** To check whether the student is able to understand the concept of similar triangles.
- **Triangle- 7**
- 12. Task:** To check whether the student is able to understand the Pythagoras Theorem and its applications.

Dimensions — Knowledge/Understanding

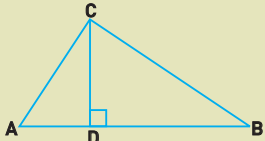
Exemplary	Competent	Developing
<ul style="list-style-type: none"> • The student understands the statement of Pythagoras Theorem and he is also able to prove it. • The student understands the converse of Pythagoras theorem and s/he is also able to prove it. <p>Student is able to solve the following question correctly :</p> <p>Q.1. In Figure, "$\angle ACB = 90^\circ$ and $CD \perp AB$.</p> <p>Prove that $\frac{BC^2}{AC^2} = \frac{BD}{AD}$</p> 	<ul style="list-style-type: none"> • The student knows the statement of Pythagoras Theorem but s/he is not able to prove it. • The student knows the statement of converse of Pythagoras Theorem but s/he is not able to prove it. • The student is able to recognise the triangles where s/he can apply the Pythagoras Theorem, but s/he is not able to apply it symbolically. 	<ul style="list-style-type: none"> • The student knows the statement of Pythagoras Theorem but s/he is not able to prove it. • The student is not able to understand the converse of Pythagoras Theorem. • The student is not able to solve the question.

Dimensions — Analytical Skill

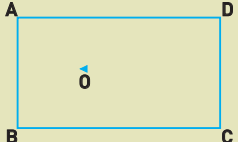
Exemplary	Competent	Developing
<ul style="list-style-type: none"> • The student has the skills to solve the following question correctly. <p>O is any point inside a rectangle ABCD (see Figure below). Prove that $OB^2 + OD^2 = OA^2 + OC^2$</p> 	<ul style="list-style-type: none"> • The student is able to make suitable construction but he is not able to apply the concept of Pythagoras Theorem to solve the question. 	<ul style="list-style-type: none"> • The student is not able to understand that the question can be solved by using Pythagoras Theorem.

Dimensions — Application

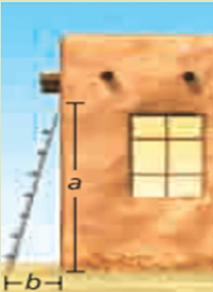
Exemplary	Competent	Developing
<ul style="list-style-type: none"> The student is able to apply his knowledge of Pythagoras Theorem to find the solution of following question : To prevent a ladder from shifting, safety experts recommend that the ratio of a : b be 4 : 1. How far from the base of the wall should you place the foot of a 5 meter ladder? Round to the nearest cm. Refer the following Figure. 	<ul style="list-style-type: none"> The student understands that he has to apply Pythagoras Theorem to solve the problem, but he is not able to understand the ratio of lengths. 	<ul style="list-style-type: none"> The student is not able to understand the question.

Readers are encouraged to develop rubrics of listed task on their own also.

• **Quadrilateral- 1**

13. Task: To check whether the student has understood the concept of angle sum property of a quadrilateral.

• **Quadrilateral- 2**

14. Task: To check whether the student has understood various properties of a quadrilateral and mid point theorem.

• **Quadrilateral- 3**

15. Task: To check whether the student has understood the concept of area of congruent figures and area of triangle and parallelogram on same base and between same parallel lines.

Dimensions — Knowledge/Understanding

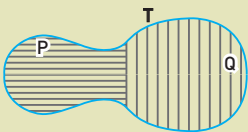
Exemplary	Competent	Developing
<ul style="list-style-type: none"> Understands that if two Figures are congruent then they have equal area. Understands that if a planar region formed by a Figure T is made up of two non-overlapping planar regions formed by figures P and Q, then $ar(T) = ar(P) + ar(Q)$. Understands that two Figures are said to be on the same base and between the same parallels, if 	<ul style="list-style-type: none"> Understands that if two figures are congruent then they have equal area. Has misunderstanding that if two figures have equal area then they are congruent. Understands that if a planar region formed by a figure T is made up of two non-overlapping planar regions formed by Figures P and Q, then $ar(T) = ar(P) + ar(Q)$. 	<ul style="list-style-type: none"> Unable to understand the relationship of congruent figures with area. Unable to understand the meaning of non-overlapping regions. Unable to understand that two Figures are said to

they have a common base (side) and the vertices (or the vertex) opposite to the common base of each figure lie on a line parallel to the base. Able to solve the following question correctly

Q.1. Which of the following Figures lie on the same base and between the same parallels. In such a case, write the common base and the two parallels.

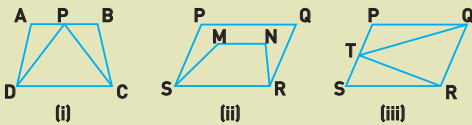

- Understands and prove that parallelograms on the same base and between the same parallels are equal in area.
- Understands and prove that parallelograms on the same base (or equal bases) and having equal areas lie between the same parallels.
- Understands and prove that two triangles on the same base (or equal bases) and between the same parallels are equal in area.
- Understands that two triangles having the same base (or equal bases) and equal areas lie between the same parallels.
- Understands that if a triangle and a parallelogram are on the same base and between the same parallels, then the area of the triangle is equal to half the area of the parallelogram
- Understands and prove that a median of a triangle divides it into two congruent triangles.

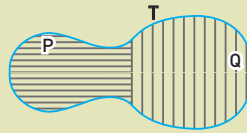

- Not able to understand the meaning of vertices (or vertex) opposite to the common base.

Able to give correct answer to part (i) of Q.1.

- Understands that parallelograms on the same base and between the same parallels are equal in area.
- Understands that parallelograms on the same base (or equal bases) and having equal areas lie between the same parallels.
- Understands that two triangles on the same base (or equal bases) and between the same parallels are equal in area.
- Understands that two triangles having the same base (or equal bases) and equal areas lie between the same parallels.
- Understands that if a triangle and a parallelogram are on the same base and between the same parallels, then the area of the triangle is equal to half the area of the parallelogram
- Understands that a median of a triangle divides it into two congruent triangles.

be on the same base and between the same parallels, if they have a common base (side) and the vertices (or the vertex) opposite to the common base of each Figure lie on a line parallel to the base.

- Unable to understand the relationship between areas of triangle and parallelogram on same or equal bases and between same parallels.

Dimensions — Analytical Skill

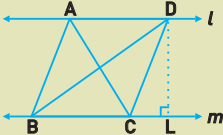
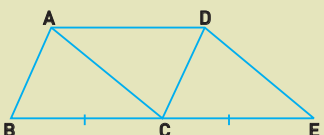
Exemplary	Competent	Developing
<ul style="list-style-type: none"> Able to solve the following questions successfully: <p>Q.1. In Fig., the area of ΔABC is given to be 18 cm^2. If the altitude DL equals 4.5 cm, find the base BC of the ΔBCD.</p>  <p>Q.2. In Fig., $ABCD$ and $ACED$ are two parallelograms. If area of ΔABC equals 12 cm^2, and the length of CE and BC are equal, find the area of the trapezium $ABED$.</p> 	<ul style="list-style-type: none"> Understands that Area of $DABC$ and area of $DBCD$ are equal but not able to apply formula for area of triangle. [Q.1.] Understands that area of trapezium is equal to area of parallelogram $ABCD$ plus area of triangle DCE, but unable to solve the questions. 	<ul style="list-style-type: none"> Unable to solve the question [Q.1.] Unable to solve the question [Q.2.]

Dimensions — Application

Exemplary	Competent	Developing
<ul style="list-style-type: none"> Applies knowledge to find the solution of following problem successfully. <p>Q.1. A villager Itwaari has a plot of land of the shape of a quadrilateral. The Gram Panchayat of the village decided to take over some portion of his plot from one of the corners to construct a Health Centre. Itwaari agrees to the above proposal with the condition that he should be given equal amount of land in lieu of his land adjoining his plot so as to form a triangular plot. Explain how this proposal will be implemented.</p>	<ul style="list-style-type: none"> Understands that question requires the application of concept that area of triangle on same base and between same parallels are same. Unable to draw Figure. 	<ul style="list-style-type: none"> Unable to solve the question.

• Circle – 1

16. Task: To check whether the student has understood the meaning of a circle and its parts.

• Circle – 2

17. Task: To check whether the student has understood the results relating to congruent arc ,

equal chords and angle subtended by them at the centre.

• Circle – 3

18. Task: To check whether the student has understood the results relating to perpendicular from the centre of a circle to its chord, and the chords of a circle equidistant from the centre.

• Circle – 4

19. Task: To check whether the student has understood the results relating to angle subtended by an arc of a circle at the centre and at the remaining part of the circle.

• Circle – 5

20. Task: To check whether the student has understood the meaning of a cyclic quadrilateral and its properties.

Dimensions — Knowledge/Understanding

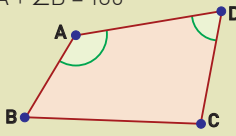
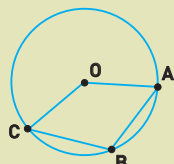
Exemplary	Competent	Developing
<ul style="list-style-type: none"> Understands the meaning of a cyclic quadrilateral. Identifies cyclic quadrilateral from a given collection of figures. States the following results : <ul style="list-style-type: none"> (i) The sum of either pair of opposite angles of a cyclic quadrilateral is 180° (ii) If the sum of a pair of opposite angles of a quadrilateral is 180°, then the quadrilateral is cyclic. 	<ul style="list-style-type: none"> Understands the meaning of cyclic quadrilateral and identifies cyclic quadrilateral from a given collection of quadrilaterals. States the result (i) correctly but does not state (ii) properly. <p>For example, states that quadrilateral ABCD is cyclic if $\angle A + \angle B = 180^\circ$</p> 	<ul style="list-style-type: none"> Understands the meaning of a cyclic quadrilateral but also describes a quadrilateral given below as cyclic.  <p>States the result (i) correctly but does not state the result (ii)</p>

Dimensions — Analytical Skill

Exemplary	Competent	Developing
<ul style="list-style-type: none"> Proves the result (i) and (ii) with proper reasoning. 	<ul style="list-style-type: none"> Verifies the results (i) and (ii) through activities. 	<ul style="list-style-type: none"> Verifies the result (i) through an activity.

Dimensions — Application

Exemplary	Competent	Developing
<ul style="list-style-type: none"> Applies the results (i) to (iii) in solving geometrical problems with reasoning and proper Figure if necessary. 	<ul style="list-style-type: none"> Applies the results (i) and (ii) in solving direct geometrical problems such as in direct geometrical problems such as in (a) and (b) 	<ul style="list-style-type: none"> Applies the result (i) correctly in (a) and finds $\angle DCB = 100^\circ$

- Applies the results (i) to (iii) in solving geometrical problems with reasoning and proper figure if necessary.

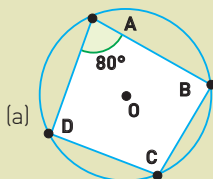

(a) What is $\angle DCB$?

(b) If $\angle A + \angle C = 170^\circ$

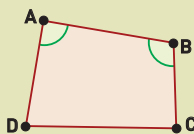

Is ABCD, a cyclic quadrilateral?

(c) In the following figure what is $\angle ADE$?

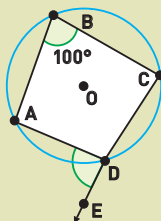

(d) O is the centre of the circle , what is the measure of $\angle BDC$?

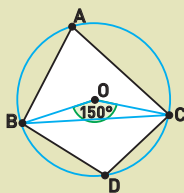

In this question , describes BODC a cyclic quadrilateral and finds $\angle BDC = 30^\circ$

(e) Is not able to prove the result : An isosceles trapezium is cyclic.
At least draws the figure correctly and understands the meaning and properties of isosceles trapezium.

(b) does not decide whether ABCD is cyclic or not.

(c) finds $\angle ADE = 80^\circ$ by understanding that $\angle B + \angle ADE = 180^\circ$

(d) finds $\angle BDC = 30^\circ$ using $\angle BOC + \angle BDC = 180^\circ$

(e) Does not understand the meaning of an isosceles trapezium and does not draw even the figure.

• Circle – 6

21. Task: To check whether the student has understood the meaning of tangent and secant to a circle and their properties.

• Constructions – 1

22. Task: To check whether the student has understood basic geometrical constructions such as drawing a line segment (angle) equal to a given line segment (angle), parallel lines, perpendicular lines and triangles with given elements.

Dimensions — Knowledge/Understanding

Exemplary	Competent	Developing
<ul style="list-style-type: none"> Understands the meaning of following constructions : <ul style="list-style-type: none"> (i) Line segment equal to given line segment. (ii) An angle equal to given angle. (iii) Perpendicular to a given line through a point on it (outside it). (iv) Bisector of a given line segment. (v) Bisector of an angle. (vi) A line parallel to a given line through a point not lying on the line. (vii) Triangle with three given sides (SSS). (viii) Triangle with two sides and included angle (SAS). (ix) Triangle with two angles and included side (ASA). (ix) Right triangle with hypotenuse and one side (RHS). 	<ul style="list-style-type: none"> Understands the meaning of constructions (i) to (x). 	<ul style="list-style-type: none"> Understands the meaning of constructions (i) to (x) except <ul style="list-style-type: none"> (a) In (iii), understands perpendicular to a given line through a point on it and not a point outside it. (b) does not understand meaning of included angle and included side in (viii) and (ix) respectively.

Dimensions — Analytical Skill

Exemplary	Competent	Developing
<ul style="list-style-type: none"> Does all the constructions (i) to (x) accurately and neatly using ruler and compass. Writes the steps of constructions. Gives justification of each constructions (i) to (x) 	<ul style="list-style-type: none"> Does all the constructions (i) to (x) using a ruler and compass. Writes the steps of construction but skips some steps in between Gives justification for constructions (i) to (vi) 	<ul style="list-style-type: none"> Does all the constructions (i) to (x) using a ruler and compass but in some cases finds convenient to use set squares and protractor specially in drawing parallel lines and in drawing angles in constructing triangles (viii) to (ix) Ignores the word 'included angle' and 'included side' in constructions (viii) and (ix) respectively. Does not give justification of any construction

Dimensions — Application

Exemplary	Competent	Developing
<ul style="list-style-type: none"> Applies the knowledge of basic constructions (mainly bisector of an angle) in constructing angles of measures 60°, 120°, 90°, 30°, 45°, 75°, 105°, 135°, 150°, 165°, and 195° using a ruler and compass accurately and neatly. 	<ul style="list-style-type: none"> Applies the knowledge of basic constructions (mainly bisector of an angle) in constructing all these angles except angle of 195° using a ruler and compass. 	<ul style="list-style-type: none"> Applies the knowledge of basic constructions (mainly bisector of an angle) and draws angles of 60°, 120°, 90°, 30°, 45°, 75°, 135° only

• **Constructions – 2**

23. Task: To check whether the student has understood how to construct triangles with base, base angle and sum / difference of two sides and with base angles and perimeter.

• **Construction – 3**

24. Task: To check whether the student has understood how to divide a line segment into given number of equal parts and how to divide a line segment in a given ratio.

• **Construction – 4**

25. Task: To check whether the student has understood how to construct a triangle similar to a given triangle with a given scale factor.

• **Construction – 5**

26. Task: To check whether the student has understood how to draw tangents to a circle from a point outside a circle.

• **Euclid Geometry – 1**

27. Task: To check whether the student has understood the need of 'undefined' terms in view of the definition given by Euclid with regard to a point line and a plane.

• **Euclid Geometry – 2**

28. Task: To check whether the student has understood the meaning of Euclid's axioms and postulates and their use in solving geometric problems.

Dimensions — Knowledge/Understanding

Exemplary	Competent	Developing
<ul style="list-style-type: none"> Understands the meaning of an axiom and postulate as suggested by Euclid. Understands that these days axioms and postulates are used interchangeably. States all the Euclid's postulates and some of the axioms. 	<ul style="list-style-type: none"> Understands the meaning of an axiom and postulate as suggested by Euclid but does not understand that postulate are specific to geometry only. States only Euclid's postulates. 	<ul style="list-style-type: none"> Does not understand the meaning of axioms and postulates. States only Euclid's fifth postulate.

Dimensions — Analytical Skill

Exemplary	Competent	Developing
<ul style="list-style-type: none"> Analyses Euclid’s postulates and appreciates the present modified versions of it and also appreciates the evolution of non-Euclidean geometry as a result of discussion on Euclid’s fifth postulate. 	<ul style="list-style-type: none"> Analyses first two postulates and appreciates their present modified versions , but not able to understand the modified version of fifth postulate. 	<ul style="list-style-type: none"> Does not find any difference between Euclid’s postulates and present modified version of postulates.

Dimensions — Application

Exemplary	Competent	Developing
<ul style="list-style-type: none"> Solves geometric problems using Euclid’s axioms and postulates through proper deductive reasoning specifying some extra assumptions. 	<ul style="list-style-type: none"> Solve geometric problems using Euclid’s axioms and postulates but does not give proper reasoning. 	<ul style="list-style-type: none"> Is not able to solve any geometric problems using Euclid’s axioms and postulates.

Conclusion

Therefore, using rubrics during evaluation is sort of diagnostic purposes. It enables in finding out the learning difficulties of a child in a particular dimension with reference to conceptual understanding, process of learning, language deficiency, etc. Using rubrics during testing helps in diagnosing the hard spots of learning as well as the learning problems. The learning problems in mathematics may be in any of the dimensions given above for example, understanding in computing and recognition of symbols where the children generally commits mistake. The teacher is supposed to find out the specific difficulty of

the child in learning a concept or a particular step in solving a problem. Therefore, if diagnosis of hard spots of learning is properly done and suitable remedial measures are taken, the learning attainment as well as learning pace of the weak and low achievers will certainly improve. Therefore, using rubrics may be a very suitable and sustainable tools for comprehensive and continuous evaluation.

In the next part of the article we will explore how the use of rubrics can encourage critical thinking and how rubrics can help us to refine our teaching skills. We will also develop rubrics for next themes trigonometry, number system, etc. in next set of articles.

References

COLUMBIA UNIVERSITY. Standards-Based Mathematics Assessment in Middle School, Rethinking Classroom Practice. Teachers College. New York and London

Continuing Professional Development – A Practical Guide for Teachers and Schools. Second Edition, London and New York in Association with The Open University.

Geometry – An Investing approach. Key Curriculum Press, CA 4608

Introduction to Rubrics – An Assessment Tool to Save Grading Time, Convey Effective Feedback and Promote Student Learning by Dannelle D. Stevens and Antonia Levi Stylus Publishing. LLC Sterling, Virginia. 2016.

Learning to Teach Mathematics in the Secondary School. Routledge, New York. NY 10016

NCERT. *Mathematics* Textbook for Class IX. New Delhi

_____. *Mathematics* Textbook for Class X. New Delhi

_____. *Teaching of Mathematics*. Focus paper, 2005. New Delhi

National Curriculum Framework– 2005. NCERT, New Delhi

Teaching Secondary Mathematics with ICT. Open University Press. McGraw-Hill Education, England

The Essentials of Mathematics, Grades 7-12. Effective Curriculum, Instruction and Assessment – Association for Supervision and Curriculum Development. Alexandria, VA 22311-1714 USA

EFFECTIVENESS OF CONTINUOUS AND COMPREHENSIVE EVALUATION (CCE) ON THE DEVELOPMENT OF HIGHER MENTAL ABILITIES IN SCIENCE STUDENTS

Nusrat Rizvi

Lecturer, SMCLK Girls PG and B.Ed College, Sikandrabad (UP)

Since independence till today many researches as well as innovative steps have been tried by secondary educational boards of India, which are mainly emphasising upon the all-round development of the students. In this context, Central Board of Secondary Education (CBSE) applied Continuous and Comprehensive Evaluation (CCE) system in Class X (2010-2011). In the present research paper, the researcher wants to see the effectiveness of CCE on the development of higher mental abilities i.e. application, analysis, synthesis and evaluation in science students.

For this purpose, a comparative study was made between the science students of Class XI from the CBSE board (who faced the CCE pattern in Class X) and the science students of the same class from UP board (who did not face the CCE pattern in Class X) in 2010-2011. For the present study, hundred students from CBSE board and 100 from UP Board of Bulandshahr district were selected through stratified random sampling technique. A test of higher mental abilities developed by the investigator on the basis of a standardised test developed by Dr D.N. Sansanwal and Dr Anuradha Joshi (1989) was administered on the students. Findings of the study indicate no significant difference in the development of higher mental abilities of science students of both the boards i.e., the CBSE Board and UP Board. The findings support the reconsideration of the applied part of CCE system followed by the CBSE Board.

Introduction

The pursuit of science is a process of unlocking the human mind. It is an exploration of mystery, beauty and method in the universe by stretching the frontiers of our imagination. We need to invoke the power of science in every sphere of life. Today, we are living in the world of science and technology. The scientists of the world have developed the technologies a lot. Due to explosion of knowledge during last few decades we are proceeding towards the technocratic age. Now science has become an integral part of our lives. Applications of science have provided us many benefits and ensured a better quality of life. Hence, each individual needs to prepare himself to

cope-up with the present situation. For this, it is very essential to develop higher mental abilities as application, analysis, synthesis and evaluation in the students. Science in India is taught as a body of complete knowledge with answers to all questions that are worth asking. But there is almost complete absence of creativity and experimentation by the students in the classroom. Principles are given more emphasis over the practice and products are given more importance over the processes of science.

Students graduate from universities with a lot of information but with little ability to apply their learning to solve the real life problems which affect them, their society and their environment. Mukherjee and Verma (2001) are of view that there

is a need to study this problem in depth and come up with a school science curriculum. The main reasons for this may be that science teaching is not child centred, artificially taught and does not arise from daily lives of children. Surveys across the globe suggest that lack of interest in science is mainly due to science being less intrinsically motivating (Global Science Forum, 2003; National Science Survey, Shukla,–2005), nature of science being cut off from real world and its content being overloaded with matters unrelated to the life of students (Hill and wheeler, 1991; Osborne and Collins, 2001). Science teaching methods are unable to provide natural curiosity in children.

Skills as the part of higher mental abilities have been mentioned at the elementary and secondary stages of education by the *National Curriculum Framework* (NCF– 2005), NCF identified some guiding principles for the planning, development and transaction of curriculum as:

1. Ensuring that learning shifts away from the rote methods.
2. Ensuring the curriculum, so that it goes beyond the textbooks.
3. Connecting knowledge to life outside the school.
4. Making examination more flexible and integrating them with the classroom life.

If evaluation is designed in such a manner that it can be used as powerful means of improving the quality of education so as to help the learner internalise the subject matter rather than to make them a storehouse of information.

The goal of science is to discover, evaluate, integrate and redefine the concepts of science. It can be achieved if emphasis is given to the

development of higher mental abilities such as comprehension, analysis, synthesis and evaluation in science students.

What is CCE?

Based on the suggestions and guidelines provided by NCF–2005, the CBSE introduced an innovation in 2010-11 in the form of CCE system for Class X. According to H.S. Shrivastava(1989), CCE has long been suggested as a conceptual and workable alternative to redress the shortcomings of the system of conventional evaluation, as it has the inherentability to test attained competencies rather than memorised content as at present. Its main purpose was to emphasise upon the all-round development of the child, continuity in evaluation and assessment of the learning and behavioural outcomes, development of the skills, emphasising the thought process, discouraging the memorisation and regular diagnosis followed by remediation.

Need for The Study

It is generally observed that at the secondary level, classroom activities mostly emphasise upon the development of low mental abilities of cognitive domain i.e. knowledge and comprehension in students. Whereas, the development of higher mental abilities i.e. application, analysis, synthesis and evaluation is ignored. When after passing Class X every student should have possessed such abilities so that he may be able to take proper decisions by analysing the situation appropriately. In order to solve real life problems, such mental

abilities should be well developed in every student but particularly in case of science students, it is essential to develop higher mental abilities properly.

The main purpose of this study is to investigate whether CCE system is playing any significant role in the development of such higher mental abilities as application, analysis, synthesis and evaluation in science students or not.

Objectives

The main objectives of the study are:

1. To study the effect of CCE on the development of higher mental abilities in science students of secondary schools.
2. To compare the higher mental abilities of science students of secondary schools following CCE pattern(CBSE) and the schools not following the CCE pattern(UP Board).
3. To compare the higher mental abilities of the science students i.e. boys and girls of the secondary schools.

Methodology

(a) Research Methodology

S.N.	Mental Abilities	Action Verbs	Item No.
1.	Application	(a) To predict (b) To compare (c) To construct (d) To assess	1,17,33,49,65,81,97 2,18,34,50,66,82,98 3,19,35,51,67,83,99 4,20,36,52,68,84,100
2.	Analysis	(a) To analyse (b) To see relationship (c) Dividing (d) To conclude	5,21,37,53,69,85,101 6,22,38,54,70,86,102 7,23,39,55,71,87,103 8,24,40,56,72,88,104

Survey method of research was employed for the present study.

(b) Sample of the study

Present study was conducted on Class XI Science students of Bulandshahr Distt. of UP to study the effectiveness CCE on the development of their higher mental abilities. 2010-11 was the year in which secondary schools affiliated by CBSE applied CCE pattern in Class X. Whereas, the schools affiliaed by UP Board did not apply CCE pattern in Class X. For present study, 160 students of Class XI; who scored between 6-9CGP or 60-90 per cent in Class X were selected from 10 secondary schools. Out of these schools, 5 schools were affiliated by UP Board and rest 5 were affiliated by CBSE, by using stratified random sampling technique.

(c) Tools Used

For measuring higher mental abilities of Secondary school science students, a test was developed by the investigator taking help of a standardized test developed by Dr D.N. Sansanwal and Dr Anuradha Joshi (1989). The 112 items of the test were framed so as to test the four action verbs of the four higher mental abilities each (i.e. application, analysis, synthesis and evaluation) in a pattern as :

3.	Synthesis	(a) To derive the abstract relations (b) To organise (c) To generalise (d) To summarise	9,25,41,57,73,89,105 1026,42,58,74,90,106 11,27,43,59,75,91,107 1228,44,60,76,92,108
4.	Evaluation	(a) To criticise (b) To evaluate (c) To avoid (d) To defend	13,29,45,61,77,93,109 14,30,46,62,78,94,110 15,31,47,63,79,95,111 16,32,48,64,80,96,112

Statistical Techniques Used

Results

Mean, Standard Deviation and 't' test were used to analyse the data.

Table 1

Sample	N	Mean	S.d.	'T'	Remarks
Students (CBSE)	100	98.71	9.44	2.13*	Significant at .05 level
Students (U.P.Board)	100	95.40	9.23		

Table 2

Mental Abilities	Action Verbs	Schools Following CCE Pattern(CBSE)				Schools Not Following CCE Pattern(UP Board)				'T'
		Mean	" X_1 "	" X_1^2 "	Ss_1	Mean	" X_2 "	" X_2^2 "	Ss_2	
1. Application	To predict	4.9	196	928	32.4	5.4	216	1224	57.6	3.84*
	To compare	6.1	244	1516	27.6	5.9	236	1332	60.4	0.83
	To construct	6.6	264	1760	17.6	6.3	252	1604	16.4	2.00
	To assess	5.5	218	1226	56.6	4.8	194	927	31.8	2.91
2. Analysis	To analyse	6.1	244	1516	27.6	5.7	228	1184	115.6	1.33
3. Synthesis	To relate	5.9	236	1332	60.4	5.1	204	1076	29.6	3.33*
	To divide	6.9	265	1700	55.6	6.4	256	1664	25.6	2.17
	To conclude	6.3	252	1601	13.4	5.5	220	1226	16.0	5.71**
	To derive	6.0	240	1476	36.0	5.1	204	1076	35.6	4.09**
4. Evaluation	To organise	5.4	216	1224	57.6	4.9	196	928	32.4	2.08
	To generalise	4.8	192	944	22.4	6.5	260	1708	18.0	3.45*
	To summarise	6.4	256	1648	9.6	6.2	248	1544	6.4	1.92
	To criticise	6.1	244	1432	56.4	6.0	240	1464	24.4	0.43
	To evaluate	5.9	236	1332	60.4	4.9	196	928	32.4	3.01*
	To avoid	5.4	216	1224	57.6	5.9	236	1332	60.4	1.78
	To defend	5.9	236	1332	60.4	4.8	192	944	22.4	4.78**

Table 3

Variables	Category	N	Mean	S.d.	'T'	Remarks
Schools Following CCE Pattern (CBSE)	Boys	65	97.02	8.89	1.42	The difference is insignificant
	Girls	35	95.34	8.66		
Schools Not Following CCE Pattern(UP board)	Boys	45	95.40	9.23	0.289	The difference is insignificant
	Girls	55	94.95	7.72		

It is evident from Table 1 that the Class XI science students of the secondary schools following CCE pattern i.e. (CBSE) scored a mean of 98.71 out of 112 items that is approximately 88.13 per cent whereas the Class XI science students of the secondary schools not following CCE pattern i.e. (UP Board) scored a mean of 94.40 out of 112 items that is approximately 84.28 per cent. On the basis of the findings it is concluded that the Class XI science students of the secondary schools following CCE pattern i.e. (CBSE) have more developed higher mental abilities.

It is observed from Table 2 that there is a significant difference in the development of higher mental abilities of Class XI science students of the secondary schools following CCE pattern i.e. (CBSE) and the Class XI science students of the secondary schools not following CCE pattern i.e. (UP Board) as to Predict($t=3.84^*$), See relationship($t=3.33^*$), to conclude($t=5.71^{**}$), to derive($t=4.09^{**}$), to Evaluate($t=4.01^{**}$) and to defend($t=4.78^{**}$). Whereas there is no significant difference in the mental abilities such as to compare($t=0.83$), to construct($t=2.00$), to assess($t=2.91$), to analyse($t=1.33$), to divide ($t=2.17$), to organise ($t=2.08$), to summarise ($t=1.92$), to criticise ($t=0.43$), to avoid ($t=1.78$)

Table 3 shows no significant difference in scores of higher mental abilities of boys and girls. It is observed from the value that the variable sex does

not play any significant role in the development of higher mental abilities.

Discussion

Going through the findings it has been found that students from both the groups scored almost same on some of the higher mental abilities as ability to compare, to construct, to assess, to divide, to organise, to summarise, to criticise and the ability to avoid. The reason may be a similar school environment for both the groups. On such ground it may be interpreted that the implementation of CCE in CBSE schools could not bring so much positive and additional change as expected. In the prescribed schedule of CCE, practical aspect of science and other subjects is emphasised more. But the actual condition was entirely different i.e. on the basis of certain projects made by the groups of the students, those were considered as their practical work and marks were given. Recent studies in India have shown that there is a shift away from science at plus two level (Patil, 2003). Students at secondary and senior secondary level should be given real laboratory experiences as it will create interest in the students for opting science. The findings support the need to renovate the applied part of the CCE so that there may be a proper development of higher mental abilities in science students.

References

- CBSE. 2009. "Examination reforms and Continuous and Comprehensive Evaluation (CCE) in the CBSE". Circular No.39. 20-09-2009.
- GLOBAL SCIENCE FORUM. 2003. Evolution of Student Interest in Science and Technology Studies. *Policy Report Retrieved*. March 19, 2008, from <http://www.oecd.org/dataoecd/16/30/36645825.pdf>.
- NCERT. 1998. National Curriculum Framework for Elementary and Secondary Education. New Delhi.
- NATIONAL CURRICULUM FRAMEWORK FOR ELEMENTARY AND SECONDARY EDUCATION – 2000, published by publication Division by the Secretary, NCERT, Sri Aurobindo Marg, New Delhi.
- OSBORNE, J. AND C. COLLINS. 2001. Pupils and Parents, Views of the School Science Curriculum. *International Journal of Science Education*. 23. 441-467.
- PATIL, R. 2003. *Science Education in India*. Retrieved, May 5, 2008, from <http://www.ias.ac.in/curresci/aug102008/238.pdf>.
- RAO, MANJULA P. Effectiveness of Continuous and Comprehensive Evaluation training programme over the Evaluation Practices of Primary School Teachers — *A DPEP Research Study in Tamil Nadu (Report)*. Regional Institute of Education, NCERT, Mysore.
- SHRIVASTAVA, H.S. 1989. *Comprehensive Evaluation in Schools*. pp. 1-146, NCERT, New Delhi.
- SHUKLA, R. 2005. Science Education, Human Resources and Public Attitude Towards Science and Technology. *India Science Report*. Retrieved, May 10, 2008, from <http://www.insaindia.org/ind%20science%20reports-main.pdf>.

SCIENCE NEWS



Jupiter's Icy Moon: Window into Europa's Ocean Lies Right at the Surface

If you could lick the surface of Jupiter's icy moon Europa, you would actually be sampling a bit of the ocean beneath. So says Mike Brown, an astronomer at the California Institute of Technology (Caltech). Brown — known as the Pluto killer for discovering a Kuiper-belt object that led to the demotion of Pluto from planetary status — and Kevin Hand from the Jet Propulsion Laboratory (JPL) have found the strongest evidence yet that salty water from the vast liquid ocean beneath Europa's frozen exterior actually makes its way to the surface.

The finding, based on some of the first data of its kind since NASA's Galileo mission (1989-2003) to study Jupiter and its moons, suggests that there is a chemical exchange between the ocean and surface, making the ocean a richer chemical environment, and implies that learning more

about the ocean could be as simple as analysing the moon's surface. The work is described in a paper that has been accepted for publication in the *Astronomical Journal*.

"We now have evidence that Europa's ocean is not isolated — that the ocean and the surface talk to each other and exchange chemicals," says Brown, the Richard and Barbara Rosenberg Professor and Professor of planetary astronomy at Caltech. "That means that energy might be going into the ocean, which is important in terms of the possibilities for life there. It also means that if you'd like to know what's in the ocean, you can just go to the surface and scrape some off."

"The surface ice is providing us a window into that potentially habitable ocean below," says Hand, Deputy Chief Scientist for solar system exploration at JPL.

Since the days of the Galileo mission, when the spacecraft showed that Europa was covered with

an icy shell, scientists have debated the composition of Europa's surface. The infrared spectrometre aboard Galileo was not capable of providing the detail needed to definitively identify some of the materials present on the surface. Now, using current technology on ground-based telescopes, Brown and Hand have identified a spectroscopic feature on Europa's surface that indicates the presence of a magnesium sulfate salt, a mineral called epsomite, that could only originate from the ocean below.

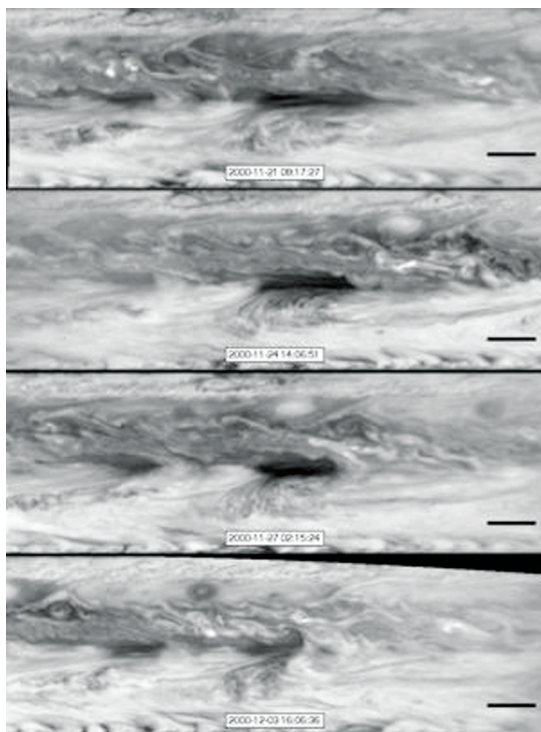

In this series of images from NASA's Cassini spacecraft, a dark, rectangular hot spot (top) interacts with a line of vortices that approaches from on the upper-right side (second panel). The interaction distorts the shape of the hot spot (third panel), leaving it diminished (bottom). (Credit: NASA/JPL-Caltech/SSI/GSFC)

"Magnesium should not be on the surface of Europa unless it's coming from the ocean," Brown says. "So that means ocean water gets onto the surface, and stuff on the surface presumably gets into the ocean water."

Europa's ocean is thought to be 100 kilometres deep and covers the entire globe. The moon remains locked in relation to Jupiter, with the same hemisphere always leading and the other trailing in its orbit. The leading hemisphere has a yellowish appearance, while the trailing hemisphere seems to be splattered and streaked with a red material.

The spectroscopic data from that red side has been a cause of scientific debate for 15 years. It is thought that one of Jupiter's largest moons, Io, spews volcanic sulfur from its atmosphere, and Jupiter's strong magnetic field sends some of that sulfur hurtling toward the trailing hemisphere of Europa, where it sticks. It is also clear from Galileo's data that there is something other than pure water ice on the trailing hemisphere's surface. The debate has focused on what that other something is — i.e., what has caused the spectroscopic data to deviate from the signature of pure water ice.

"From Galileo's spectra, people knew something was there besides water. They argued for years over what it might be — sodium sulfate, hydrogen sulfate, sodium hydrogen carbonate, all these things that look more or less similar in this range of the spectrum," says Brown. "But the really difficult thing was that the spectrometre on the Galileo spacecraft was just too coarse."

Brown and Hand decided that the latest spectrometres on ground-based telescopes could

improve the data pertaining to Europa, even from a distance of about 400 million miles. Using the Keck II telescope on Mauna Kea — which is outfitted with adaptive optics to adjust for the blurring effect of Earth's atmosphere — and its OH-Suppressing Infrared Integral Field Spectrograph (OSIRIS), they first mapped the distribution of pure water ice versus anything else on the moon. The spectra showed that even Europa's leading hemisphere contains significant amounts of nonwater ice. Then, at low latitudes on the trailing hemisphere — the area with the greatest concentration of the nonwater ice material — they found a tiny dip in the spectrum that had never been detected before.

"We now have the best spectrum of this thing in the world," Brown says. "Nobody knew there was this little dip in the spectrum because no one had the resolution to zoom in on it before."

The two researchers racked their brains to come up with materials that might explain the new spectroscopic feature, and then tested everything from sodium chloride to Drano in Hand's lab at JPL, where he tries to simulate the environments found on various icy worlds. "We tried to think outside the box to consider all sorts of other possibilities, but at the end of the day, the magnesium sulfate persisted," Hand says.

Some scientists had long suspected that magnesium sulfate was on the surface of Europa. But, Brown says, "the interesting twist is that it doesn't look like the magnesium sulfate is coming from the ocean." Since the mineral he and Hand found is only on the trailing side, where the moon is being bombarded with sulfur from Io, they believe that there is a magnesium-bearing mineral everywhere on Europa that produces

magnesium sulfate in combination with sulfur. The pervasive magnesium-bearing mineral might also be what makes up the nonwater ice detected on the leading hemisphere's surface.

Brown and Hand believe that this mystery magnesium-bearing mineral is magnesium chloride. But magnesium is not the only unexpected element on the surface of Europa. Fifteen years ago, Brown showed that Europa is surrounded by an atmosphere of atomic sodium and potassium, presumably originating from the surface. The researchers reason that the sodium and potassium chlorides are actually the dominant salts on the surface of Europa, but that they are not detectable because they have no clear spectral features.

The scientists combined this information with the fact that Europa's ocean can only be one of two types — either sulfate-rich or chlorine-rich. Having ruled out the sulfate-rich version since magnesium sulfate was found only on the trailing side, Brown and Hand hypothesize that the ocean is chlorine-rich and that the sodium and potassium must be present as chlorides.

Therefore, Brown says, they believe the composition of Europa's sea closely resembles the salty ocean of Earth. "If you could go swim down in the ocean of Europa and taste it, it would just taste like normal old salt," he says.

Hand emphasises that, from an astrobiology standpoint, Europa is considered a premier target in the search for life beyond Earth; a NASA-funded study team led by JPL and the Johns Hopkins University Applied Physics Laboratory have been working with the scientific community to identify options to explore Europa further. "If

we've learned anything about life on Earth, it's that where there's liquid water, there's generally life," Hand says. "And of course our ocean is a nice salty ocean. Perhaps Europa's salty ocean is also a wonderful place for life."

The *Astronomical Journal* paper is titled "Salts and Radiation Products on the Surface of Europa." The work was supported, in part, by the NASA Astrobiology Institute through the Astrobiology of Icy Worlds node at JPL.

Source: *Science Daily Online*

New Cancer Diagnostic Technique Debuts

Cancer cells break down sugars and produce the metabolic acid lactate at a much higher rate than normal cells. This phenomenon provides a telltale sign that cancer is present, via diagnostics such as PET scans, and possibly offers an avenue for novel cancer therapies. Now a team of Chilean researchers at the Centro de Estudios Científicos (CECs), with the collaboration of Carnegie's Wolf Frommer, has devised a molecular sensor that can detect levels of lactate in individual cells in real time.

Prior to this advance, no other measurement method could non-invasively detect lactate in real time at the single-cell level. The work, published in the open access journal *PLoS ONE*, is a boon to understanding how different types of cells go awry when cancer hits.

"Over the last decade, the Frommer lab at Carnegie has pioneered the use of Förster Resonance Energy Transfer, or FRET, sensors to measure the concentration and flow of sugars in individual cells with a simple fluorescent colour

change. This has started to revolutionise the field of cell metabolism," explained CECs researcher Alejandro San Martín, lead author of the article. "Using the same underlying physical principle and inspired by the sugar sensors, we have now invented a new type of sensor based on a transcriptional factor. A molecule that normally helps bacteria to adapt to its environment has now been tricked into measuring lactate for us."

Lactate shuttles between cells and inside cells as part of the normal metabolic process. But it is also involved in diseases that include inflammation, inadequate oxygen supply to cells, restricted blood supply to tissues, and neurological degradation, in addition to cancer.

"Standard methods to measure lactate are based on reactions among enzymes, which require a large number of cells in complex cell mixtures," explained Felipe Barros, leader of the project. "This makes it difficult or even impossible to see how different types of cells are acting when cancerous. Our new technique lets us measure the metabolism of individual cells, giving us a new window for understanding how different cancers operate. An important advantage of this technique is that it may be used in high-throughput format, as required for drug development."

This work used a bacterial transcription factor — a protein that binds to specific DNA sequences to control the flow of genetic information from DNA to mRNA — as a means to produce and insert the lactate sensor. They turned the sensor on in three cell types: normal brain cells, tumor brain cells, and human embryonic cells. The sensor was able to quantify very low concentrations of lactate, providing an unprecedented sensitivity and range of detection.

The researchers found that the tumor cells produced lactate 3-5 times faster than the non-tumor cells. "The high rate of lactate production in the cancer cell is the hallmark of cancer metabolism," remarked Frommer. "This result paves the way for understanding the nuances of cancer metabolism in different types of cancer and for developing new techniques for combatting this scourge."

In addition, the biosensors promise to solve an old controversy. While some studies have suggested the glucose provides the fuel for the brain, recent research has provided evidence that lactate feeds energy metabolism in neurons. Oxidation of lactate can be used to produce large amount of ATP — the coenzyme that carries energy in cells. The Barros and Frommer teams are excited about the solving this enigma with the use of their new sensors, together with the previously developed glucose sensors. Recently, a collaboration between the two labs led to the patenting of the first method capable of measuring the rate of glucose consumption in single cells.

Source: *Science Daily Online*

Creating your Own Animated 3-D Characters and Scenes for the Web

To show spatial animations on websites, developers so far have had only two options: to use special software or to implement it from scratch. Computer scientists at Saarland University have developed a declarative markup language which facilitates the creation of distinct spatial animations and ensures their smooth replay in the web browser.

The researchers will show their results at the trade fair Cebit in Hannover starting on 5 March (Hall 9, booth F34).



Computer scientists from Saarland University enable web developers to shape the Internet in its third dimension in an easier way. (Credit: Image courtesy of University Saarland)

It could be a grotto. Light is glowing up from below and gives the moving waves a glance of an opal under the sunlight. "This computer graphic was written with our new description language by a school boy in not more than two hours after a briefly reading of the instructions," explains Felix Klein, doctoral candidate at the chair of Computer Graphics at Saarland University. As Klein is moving three slide switches with the mouse which are placed under the wave graphic on the display, the water is transforming. Now, the waves are spreading circularly from the center point, as if someone had thrown a pebble into the middle of the water.

"Xflow" is the name of the new description language developed by Klein and his colleagues. It makes it not only possible to describe such three-dimensional appearing animations more easily but also manages it that the required data is efficiently processed by the central processing unit and the graphics processor. Hence, the

animation is running in the browser fluidly. “Up till now, this has not been that easy,” explains Philipp Slusallek, Professor for Computer Graphics at Saarland University. “Meanwhile, even a mobile phone has enough computing power to play spatial data content from the internet. But the web technologies, necessary for using 3D content on the web, and the machine-orientated programming of graphic hardware have not found a common ground yet,” so Slusallek, who also works as the Scientific Director of the German Research Center for Artificial Intelligence and as Director of Research of the Intel Visual Computing Institute (IVCI) in Saarbrücken.

Xflow shall help to fill this gap. It’s declarative. What means in this case, that the developers rather describe which pattern synthesis effects shall get constructed, than to wrack their brains about how these can be computed in detail. In its appearance, Xflow resembles to the languages HTML and Javascript. With Javascript, it is indeed possible to describe three-dimensional data contents; however the data, which is needed for that, cannot be computed offhand in a parallel and thus efficient way. Xflow allows the so-called parallelisation automatically due to its structure. Neither, the programmers need to worry about this, nor about the allocation of disk space. Other software systems can also accomplish this, but with them only a limited number of shifts, textures and pattern effects can be described.

Xflow offers an alternative by defining a multiplicity of small components, so-called operators, of which complex animations can be created easily. In doing so, it uses the service of the HTML-upgrading XML3D, which allows the easy embedding of spatial data contents on

websites. It was also developed by Philipp Slusallek and his team. He is confident: “After XML3D we took the next step forward to present three-dimensional contents on the internet in such an easy way as it’s already the case with embedded Youtube videos.” The development of Xflow has been supported by the IVCI of Saarland University and by the German Research Center for Artificial Intelligence (DFKI).

Source: *Science Daily Online*

In Greenland and Antarctic Tests, Yeti Helps Conquer Some ‘Abominable’ Polar Hazards

A century after Western explorers first crossed the dangerous landscapes of the Arctic and Antarctic, researchers funded by the National Science Foundation (NSF) have successfully deployed a self-guided robot that uses ground-penetrating radar to map deadly crevasses hidden in ice-covered terrains.

Deployment of the robot—dubbed Yeti—could make Arctic and Antarctic explorations safer by revealing unseen fissures buried beneath ice and snow that could potentially claim human lives and expensive equipment.

Researchers say Yeti opens the door to making polar travel safer for crews that supply remote scientific research stations. Attempts have been made by researchers in the polar regions to use robots for tasks such as searching for meteorites in Antarctica. However, researchers who have worked with Yeti say it is probably the first robot to successfully deploy in the field that is able to identify hazards lurking under the thin cover of snow.

These findings are based on deployments of Yeti in Greenland's Inland Traverse, an over-ice supply train from Thule in the north of Greenland to NSF's Summit Station on the ice cap, and in NSF's South Pole Traverse, a 1,031-mile, over-ice trek from McMurdo Station in Antarctica to the South Pole.

A team of researchers from the US Army's Cold Regions Research and Engineering Laboratory (CRREL) and the Thayer School of Engineering at Dartmouth College, along with a student at Stanford University's neuroscience programme, recently published their findings in the *Journal of Field Robotics*.

"Polar exploration is not unlike space missions; we put people into the field where it is expensive and it is dangerous to do science," said CRREL's James Lever.

Using Yeti—and potential follow-on devices that Lever expects may be developed in the future by improving on the Yeti template—has value not only in reducing some of the danger to human beings working in polar environments. Deploying Yeti and machines like it also plays to the strength of robots, which are well suited for learning and performing repetitive tasks more efficiently than humans.

Lever added that robots like Yeti not only improve safety; they also have the potential to reduce the costs of logistical support of science in the remote polar regions and extend the capabilities of researchers.

Yeti was developed with funding from the National Aeronautics and Space Administration's Jet Propulsion Laboratory.

Students of Lever and Laura Ray, at Dartmouth, also a principal investigator on the Yeti project and a co-author of the paper, designed and created a predecessor to Yeti—called Cool Robot—that was funded by NSF's Division of Polar Programmes to conduct work in Antarctica.

Under a separate NSF grant, researchers plan to deploy Cool Robot this summer to circumnavigate NSF's Summit Station on the Greenland ice sheet, taking atmospheric samples as it goes. The solar-powered, four-wheel-drive Cool Robot led to Yeti's success, while helping the researchers meet NSF's goal of integrating research and education.

"Our focus with Yeti is on improving operational efficiency," Lever said. "But more generally, robotics has the potential to produce more science with more spatial and temporal coverage for less money. We're not going to replace the scientists. But what we can do is extend their reach and add to the science mission."

Yeti is an 81-kilogram (180-pound) battery powered, four-wheel drive vehicle, about a metre across, that is capable of operating in temperatures as low as -30 Celsius (-20 Fahrenheit). Yeti uses Global Positioning System coordinates to navigate and to plot the position of under-ice hazards.

That work—and the accompanying risks—in the past has fallen exclusively to human crews using ground-penetrating radar to map the under-ice features.

Crevasses often can span widths of 9 metres (30 feet) or more and reach depths of up to 60 metres (200 feet). Snow often accumulates in such a way

that it forms unstable bridges over the crevasse, obscuring them from view.

Prior to the development of Yeti, a vehicle pushing a GPR unit would move ahead of a traverse to attempt to detect crevasses. Although the radar was pushed ahead of the vehicle, giving some margin of advanced warning and safety, the system is none-the-less dangerous and stressful for the crews, especially when traversing long distances.

In addition to having the potential to greatly reduce the danger to humans, the Yeti project also has helped advance research into how robots learn, as the research team uses the data gathered by Yeti during hundreds of crevasse encounters to refine algorithms that will allow machines in future to automatically map and avoid crevasses on their own.

Yeti has also proven itself adept at tasks that were not originally envisioned for it.

During the 2012-13 Antarctic research season, Yeti was used to map ice caves on the slopes of Mount Erebus, the world's southernmost active volcano.

The ice caves are attracting increasingly more scientific attention. Volcanologists are interested in the volcano's chemical outgassing through fissures on its flanks, and biologists are interested in what sort of microbial life might exist in these discrete environments, which are much warmer and far more humid than the frigid, wind-sculpted surface.

In a deployment that coincided with the 100th anniversary of the arrival of the first explorers at the geographic South Pole in the 2011-2012 research season, Yeti repeatedly and uniformly executed closely spaced survey grids to find known, but inaccurately mapped, buried hazards.

The robot mapped out the long-abandoned original South Pole research station, built in the late 1950s and subsequently buried under the Antarctic ice sheet by years of snowfall and drift. A previous, less refined survey of the site by a human crew had only generally identified the outline of the major buildings. The Yeti-based survey generated a map detailed enough to allow crews to directly access the corners of structures near the ice surface in order to safely demolish them.

Source: *Science Daily Online*

Making Fuel from Bacteria

In the search for the fuels of tomorrow, Swedish researchers are finding inspiration in the sea. Not in offshore oil wells, but in the water where blue-green algae thrive.

The building blocks of blue-green algae – sunlight, carbon dioxide and bacteria – are being used by researchers at KTH Royal Institute of Technology in Stockholm to produce butanol, a hydrocarbon-like fuel for motor vehicles.

The advantage of butanol is that the raw materials are abundant and renewable, and production has the potential to be 20 times more efficient than making ethanol from corn and sugar cane.

Using genetically-modified cyanobacteria, the team linked butanol production to the algae's natural metabolism, says Paul Hudson, a researcher at the School of Biotechnology at KTH who leads the research. "With relevant genes integrated in the right place in cyanobacteria's genome, we have tricked the cells to produce butanol instead of fulfilling their normal function," he says.

The team demonstrated that it can control butanol production by changing the conditions in the surrounding environment. This opens up other opportunities for control, such as producing butanol during specific times of day, Hudson says.



Paul Hudson, a researcher at the School of Biotechnology at KTH, shows the algae used to make fuel. (Credit: Image courtesy of KTH The Royal Institute of Technology)

Hudson says that it could be a decade before production of biofuel from cyanobacteria is a commercial reality.

“We are very excited that we are now able to produce biofuel from cyanobacteria. At the same time we must remember that the manufacturing process is very different from today’s biofuels,” he says. “We need to improve the production hundredfold before it becomes commercially viable.

Already, there is a demonstrator facility in New Mexico, US for producing biodiesel from algae, which is a more advanced process, Hudson says.

One of Sweden’s leading biotechnology researchers, Professor Mathias Uhlén at KTH, has overall responsibility for the project. He says that the use of engineering methods to build genomes of microorganisms is a relatively new area.

A bacterium that produces cheap fuel by sunlight and carbon dioxide could change the world.

Hudson agrees. “One of the problems with biofuels we have today, that is, corn ethanol, is that the price of corn rises slowly while jumping up and down all the time and it is quite unpredictable,” he says. “In addition, there is limited arable land and corn ethanol production is also influenced by the price of oil, since corn requires transport.

“Fuel based on cyanobacteria requires very little ground space to be prepared. And the availability of raw materials - sunlight, carbon dioxide and seawater - is in principle infinite,” Hudson says.

He adds that some cyanobacteria also able to extract nitrogen from the air and thus do not need any fertiliser.

The next step in the research is to ensure that cyanobacteria produce butanol in larger quantities without it dying of exhaustion or butanol, which they cannot withstand particularly well. After that, more genes will have to be modified so that the end product becomes longer hydrocarbons that can fully function as a substitute for gasoline. And finally, the process must be executed outside of the lab and scaled up to work in industry.

There are also plans to develop fuel from cyanobacteria that are more energetic and therefore particularly suitable for aircraft engines.

The project is formally called Forma Center for Metabolic Engineering, and it involves researchers Chalmers University in Sweden. It has received about EUR 3 million from the nonprofit Council Formas.

Source: *Science Daily Online*

Fungi may be Able to Replace Plastics One Day

Fungi, with the exception of shitake and certain other mushrooms, tend to be something we associate with moldy bread or dank-smelling mildew. But they really deserve more respect. Fungi have fantastic capabilities and can be grown, under certain circumstances, in almost any shape and be totally biodegradable. And, if this weren't enough, they might have the potential to replace plastics one day. The secret is in the mycelia.

Union College Biology Professor Steve Horton likens this mostly underground portion of fungi (the mushrooms that pop up are the reproductive structures) to a tiny biological chain of tubular cells.

"It's this linked chain of cells that's able to communicate with the outside world, to sense what's there in terms of food and light and moisture," he said. "Mycelia can take in nutrients from available organic materials like wood and use them as food, and the fungus is able to grow as a result."

"When you think of fungi and their mycelia, their function — ecologically — is really vital in degrading and breaking things down," Horton added. "Without fungi, and bacteria, we'd be I don't know how many meters deep in waste, both plant matter and animal tissue."

Looking something like extremely delicate, white dental floss, mycelia grow in, through and around just about any organic substrate. Whether it's leaves or mulch, mycelia digest these natural materials and can also bind everything together in a cohesive mat. And these mats can be grown in

molds, such as those that might make a packing carton.

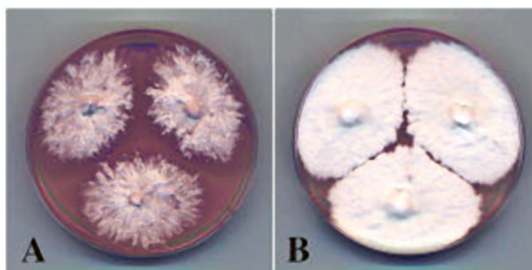

Fungi have fantastic capabilities and can be grown, under certain circumstances, in almost any shape and be totally biodegradable. And, if this weren't enough, they might have the potential to replace plastics one day. (Credit: Union College)

Ecovative Design, in Green Island, N.Y., is harnessing this particular mycological power and is being helped by Horton, and another Union researcher, Ronald Bucinell, Associate Professor of mechanical engineering.

Ecovative uses several species of fungi to manufacture environmentally-friendly products. The process starts with farming byproducts, like cotton gin waste; seed hulls from rice, buckwheat and oats; hemp or other plant materials. These are sterilised, mixed with nutrients and chilled. Then the mycelia spawn are added and are so good at proliferating that every cubic inch of material soon contains millions of tiny fungal fibers.

This compact matrix is then grown in a mould the shape of whatever item Ecovative is making. Once the desired texture, rigidity and other characteristics of the product are achieved, it's popped from its mold and heated and dried to kill the mycelia and stop its growth.

The all-natural products, the creation of which can take less than 5 days, have no allergy

concerns and are completely non-toxic. More impressive is the fact that they're also impervious to fire (to a point), and just as water resistant as Styrofoam, but they won't sit around taking up space in a landfill. They are also more UV-stable than foam since they are not petrochemical based, and won't emit volatile organic compounds. When exposed to the right microbes, they will break down in 180 days in any landfill or backyard.

Mycelium is comparatively inexpensive too as it can grow on farm waste that can't be fed to animals or burned for fuel. Better yet, the fungi can be propagated without sunlight or much human oversight in simple trays at room temperature — no immense greenhouses with costly temperature-control systems needed. It also means a smaller carbon footprint and Ecovative is hoping to the point where they can displace all plastics and foams in the market.

And this is where Union professors and researchers, Steve Horton and Ronald Bucinell, are aiding them in this effort. In Horton's lab, he and his students are tinkering with a species of fungus Ecovative uses in its manufacturing.

"We manipulate one strain in various ways to see if we can make versions of the fungus to suit certain applications the company has in mind," Horton said. "For example, it might be helpful if Ecovative has certain versions that grow faster."

Associate Professor of Mechanical Engineering Ronald Bucinell and his students also offer critical support to Ecovative's research and development pipeline. Bucinell's particular expertise is in experimental mechanics and the mechanics of reinforced materials and is tasked with seeing how strong sample material is under different parameters. This includes determining whether

mycelia bind better to one plant material or another; and does the way it's treated — with heat or something else — make it stronger or weaker.

Whether it is packaging or PCR (a genetics tool), the Ecovative founders are grateful for their higher-ed partners.

"Steve is unique because his research over the last 28 years has focused on the effect of genetic pathways on fungal physiology, which factors greatly into what we can do with mycelia," Ecovative co-founder Gavin McIntyre said. "And Ron is one of the foremost experts in composites design. To have these two scientists so close to our facilities in Green Island is highly valuable."

"This is a brand new field in materials, and collaboration allows us to learn a lot, and quickly," McIntyre continued. "That's really important when you're trying to replace plastics."

The project is supported through funding from NSF and NYSERDA.

Source: [Science Daily Online](#)

'Monster' Starburst Galaxies Discovered in Early Universe

Astronomers using the Atacama Large Millimeter/submillimeter Array (ALMA) telescope have discovered starburst galaxies earlier in the Universe's history than they were previously thought to have existed. These newly discovered galaxies represent what today's most massive galaxies looked like in their energetic, star-forming youth.

The results, published in a set of papers to appear in the journal *Nature* and in the *Astrophysical*

Journal, will help astronomers better understand when and how the earliest massive galaxies formed.

The most intense bursts of star birth are thought to have occurred in the early Universe in massive, bright galaxies. These starburst galaxies converted vast reservoirs of gas and dust into new stars at a furious pace — many thousands of times faster than stately spiral galaxies like our own Milky Way.

The international team of researchers first discovered these distant starburst galaxies with the National Science Foundation's 10-metre South Pole Telescope. Though dim in visible light, they were glowing brightly in millimeter wavelength light, a portion of the electromagnetic spectrum that the new ALMA telescope was designed to explore.

Using only 16 of ALMA's eventual full complement of 66 antennas, the researchers were able to precisely determine the distance to 18 of these galaxies, revealing that they were among the most distant starburst galaxies ever detected, seen when the Universe was only one to three billion years old. These results were surprising because very few similar galaxies had previously been discovered at similar distances, and it wasn't clear how galaxies that early in the history of the Universe could produce stars at such a prodigious rate.

"The more distant the galaxy, the further back in time one is looking, so by measuring their distances we can piece together a timeline of how vigorously the Universe was making new stars at different stages of its 13.7 billion-year history," said Joaquin Vieira a postdoctoral scholar at

Caltech who led the team and is lead author of the *Nature* paper.

In fact, two of these galaxies are the most distant starburst galaxies published to date — so distant that their light began its journey when the Universe was only one billion years old. Intriguingly, emission from water molecules was detected in one of these record-breakers, making it the most distant detection of water in the Universe published to date.

"ALMA's sensitivity and wide wavelength range mean we could make our measurements in just a few minutes per galaxy — about one hundred times faster than before," said Axel Weiss of the Max-Planck-Institute for Radioastronomy in Bonn, Germany, who led the work to measure the distances to the galaxies. "Previously, a measurement like this would be a laborious process of combining data from both visible-light and radio telescopes."

The galaxies found in this study have relatives in the local Universe, but the intensity of star formation in these distant objects is unlike anything seen nearby. "Our most extreme galactic neighbors are not forming stars nearly as energetically as the galaxies we observed with ALMA," said Vieira. "These are monstrous bursts of star formation."

The new results indicate these galaxies are forming 1,000 stars per year, compared to just 1 per year for our Milky Way galaxy.

This unprecedented measurement was made possible by gravitational lensing, in which the light from a distant galaxy is distorted and magnified by the gravitational force of a nearer foreground galaxy. "These beautiful pictures from ALMA

show the background galaxies warped into arcs of light known as Einstein rings, which encircle the foreground galaxies,” said Yashar Hezaveh of McGill University in Montreal, Canada, who led the study of the gravitational lensing. “The dark matter surrounding galaxies half-way across the Universe effectively provides us with cosmic telescopes that make the very distant galaxies appear bigger and brighter.”

Analysis of this gravitational distortion reveals that some of the distant star-forming galaxies are as bright as 40 trillion Suns, and that gravitational lensing has magnified this light by up to 22 times. Future observations with ALMA using gravitational lensing can take a more detailed look at the distribution of dark matter surrounding galaxies.

“This is an amazing example of astronomers from around the world collaborating to make an exciting discovery with this new facility,” said Daniel Marrone with the University of Arizona, principal investigator of the ALMA gravitational lensing study. “This is just the beginning for ALMA and for the study of these starburst galaxies. Our next step is to study these objects in greater detail and figure out exactly how and why they are forming stars at such prodigious rates.”

ALMA, an international astronomy facility, is a partnership of Europe, North America and East Asia in cooperation with the Republic of Chile. ALMA construction and operations are led on behalf of Europe by ESO, on behalf of North America by the National Radio Astronomy Observatory (NRAO), and on behalf of East Asia by the National Astronomical Observatory of Japan (NAOJ). The Joint ALMA Observatory (JAO) provides the unified leadership and management

of the construction, commissioning and operation of ALMA.

The National Radio Astronomy Observatory is a facility of the National Science Foundation, operated under cooperative agreement by Associated Universities, Inc.

Source: *Science Daily Online*

‘Hot Spots’ Ride a Merry-Go-Round On Jupiter

In the swirling canopy of Jupiter’s atmosphere, cloudless patches are so exceptional that the big ones get the special name “hot spots.” Exactly how these clearings form and why they’re only found near the planet’s equator have long been mysteries. Now, using images from NASA’s Cassini spacecraft, scientists have found new evidence that hot spots in Jupiter’s atmosphere are created by a Rossby wave, a pattern also seen in Earth’s atmosphere and oceans. The team found the wave responsible for the hot spots glides up and down through layers of the atmosphere like a carousel horse on a merry-go-round.

“This is the first time anybody has closely tracked the shape of multiple hot spots over a period of time, which is the best way to appreciate the dynamic nature of these features,” said the study’s lead author, David Choi, a NASA Postdoctoral Fellow working at NASA’s Goddard Space Flight Center in Greenbelt, Md. The paper is published online in the April issue of the journal *Carus*.

Choi and his colleagues made time-lapse movies from hundreds of observations taken by Cassini during its flyby of Jupiter in late 2000, when the

spacecraft made its closest approach to the planet. The movies zoom in on a line of hot spots between one of Jupiter's dark belts and bright white zones, roughly 7 degrees north of the equator. Covering about two months (in Earth time), the study examines the daily and weekly changes in the sizes and shapes of the hot spots, each of which covers more area than North America, on average.

Much of what scientists know about hot spots came from NASA's Galileo mission, which released an atmospheric probe that descended into a hot spot in 1995. This was the first, and so far only, in-situ investigation of Jupiter's atmosphere.

"Galileo's probe data and a handful of orbiter images hinted at the complex winds swirling around and through these hot spots, and raised questions about whether they fundamentally were waves, cyclones or something in between," said Ashwin Vasavada, a paper co-author who is based at NASA's Jet Propulsion Laboratory in Pasadena, Calif., and who was a member of the Cassini imaging team during the Jupiter flyby. "Cassini's fantastic movies now show the entire life cycle and evolution of hot spots in great detail."

Because hot spots are breaks in the clouds, they provide windows into a normally unseen layer of Jupiter's atmosphere, possibly all the way down to the level where water clouds can form. In pictures, hot spots appear shadowy, but because the deeper layers are warmer, hot spots are very bright at the infrared wavelengths where heat is sensed; in fact, this is how they got their name.

One hypothesis is that hot spots occur when big drafts of air sink in the atmosphere and get

heated or dried out in the process. But the surprising regularity of hot spots has led some researchers to suspect there is an atmospheric wave involved. Typically, eight to 10 hot spots line up, roughly evenly spaced, with dense white plumes of cloud in between. This pattern could be explained by a wave that pushes cold air down, breaking up any clouds, and then carries warm air up, causing the heavy cloud cover seen in the plumes. Computer modeling has strengthened this line of reasoning.

From the Cassini movies, the researchers mapped the winds in and around each hot spot and plume, and examined interactions with vortices that pass by, in addition to wind gyres, or spiraling vortices, that merge with the hot spots. To separate these motions from the jet stream in which the hot spots reside, the scientists also tracked the movements of small "scooter" clouds, similar to cirrus clouds on Earth. This provided what may be the first direct measurement of the true wind speed of the jet stream, which was clocked at about 300 to 450 mph (500 to 720 kilometres per hour) — much faster than anyone previously thought. The hot spots amble at the more leisurely pace of about 225 mph (362 kilometres per hour).

By teasing out these individual movements, the researchers saw that the motions of the hot spots fit the pattern of a Rossby wave in the atmosphere. On Earth, Rossby waves play a major role in weather. For example, when a blast of frigid Arctic air suddenly dips down and freezes Florida's crops, a Rossby wave is interacting with the polar jet stream and sending it off its typical course. The wave travels around our planet but periodically wanders north and south as it goes.

The wave responsible for the hot spots also circles the planet west to east, but instead of wandering north and south, it glides up and down in the atmosphere. The researchers estimate this wave may rise and fall 15 to 30 miles (24 to 50 kilometres) in altitude.

The new findings should help researchers understand how well the observations returned by the Galileo probe extend to the rest of Jupiter's atmosphere. "And that is another step in answering more of the questions that still surround hot spots on Jupiter," said Choi.

Source: *Science Daily Online*

Stressed Proteins can Cause Blood Clots for Hours

New research from Rice University, Baylor College of Medicine (BCM) and the Puget Sound Blood Center (PSBC) has revealed how stresses of flow in the small blood vessels of the heart and brain could cause a common protein to change shape and form dangerous blood clots. The scientists were surprised to find that the proteins could remain in the dangerous, clot-initiating shape for up to five hours before returning to their normal, healthy shape.

The study — the first of its kind — focused on a protein called von Willebrand factor, or VWF, a key player in clot formation. A team led by Rice physicist Ching-Hwa Kiang found that "shear" forces, like those found in small arteries of patients with atherosclerosis, cause snippets of nonclotting VWF to change into a clot-forming shape for hours at a time. The finding appears online this week in *Physical Review Letters*.

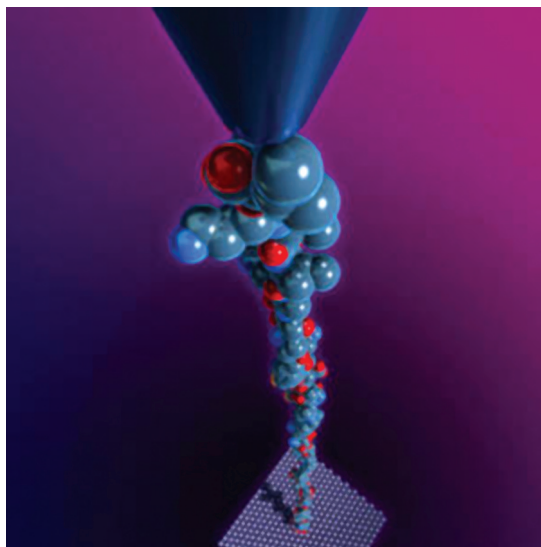

Rice University researchers in the lab of Ching-Hwa Kiang use the bobbing needle from an atomic force microscope to grab and pull individual protein molecules. By stretching the proteins, Kiang's team can measure the precise physical forces that shape them. (Credit: C. Kiang/Rice University)

"When I first heard what Dr Kiang's team had found, I was shocked," said blood platelet expert Dr Joel Moake, a study co-author who holds joint appointments at Rice and BCM. Moake, whose research group was the first to describe how high shear stress could cause platelets to stick to VWF, said, "I had thought that the condition might last for such a short time that it would be unmeasurable. No one expected to find that this condition would persist for hours. This has profound clinical implications."

Kiang, Associate Professor of physics and astronomy and of bioengineering, studies the forces involved in protein folding. Proteins are the workhorses of biology. Tens of thousands are produced each second in every living cell, and

each of these folds into a characteristic shape within moments of its creation. Despite its ubiquity, protein folding is an immensely complex process that is shrouded in mystery.

Kiang is a pioneer in the use of atomic force microscopes (AFM) to shed light on the fundamental physical processes involved in protein folding. The AFM has a tiny needle with a tip measuring just a few atoms across. The needle is suspended from a tiny arm that bobs up and down over a surface. Kiang's team uses the bobbing needle to grab and pull apart individual protein molecules. By stretching these like rubber bands, her team has shown it can measure the precise physical forces that hold them in their folded shape.

"In this study, we did more than just measure the forces; we used those measurements to see what state the molecule was in," Kiang said. "In this way, we were able to study the dynamics of the molecule, to see how it changed over a period of time."

Moake, a senior research scientist in bioengineering at Rice and professor of medicine at BCM, said the work is vitally important because it helps explain the workings of VWF.

"VWF is synthesised in the cells that line the walls of blood vessels, and it's stored there until the cells get signals that the vessels are in danger of injury," Moake said. "In response to those stimuli, the cell secretes VWF. It's a long protein, and one end remains anchored to the cell while the rest unfurls from the wall like a streamer."

The act of unfurling makes VWF sticky for platelets, and that begins the process of hemostasis, which prevents people from bleeding

to death when blood vessels are damaged by cuts and wounds.

"The body recognises when clotting must stop — when there are too many strings, too much sticking, too many platelet clumps — and it uses an enzyme to clip the long VWF strings," Moake explained. "First, it makes large, soluble versions of the strings that remain somewhat sticky, and then these large soluble portions of VWF are reduced into smaller subunits of VWF that circulate in the plasma."

Under normal conditions, these circulating subunits, which are called PWWF, fold into compact shapes and cease to be sticky to platelets. However, previous research had shown that a type of physical stress called "shear" — which can arise in partially occluded arterial blood vessels with high flow rates — could cause PWWF to become sticky to platelets.

"That's all we knew," Moake said. "We didn't know how the conformation of the PWWF protein changed. That is why Dr Kiang's research is so important and makes it more likely that therapeutic interventions can be more rationally designed."

To study the problem, Kiang's lab worked closely with Moake's team at Rice's BioScience Research Collaborative and with researchers from the laboratory of co-author Jing-fei Dong, formerly of BCM and now at PSBC in Seattle. Moake's and Dong's groups prepared samples of PWWF, subjecting some to the shear stresses known to induce clot formation. Kiang's team used AFMs to test the samples. Through a combination of experiments and deductive reasoning, her team determined exactly which portion of PWWF changed its conformation during shear stress. They also

determined how long the protein remained partially unfurled before relaxing into its natural shape.

“The next step will be to design new experiments that allow us to monitor the proteins as they bind to platelets and initiate clot formation,” Kiang said. “That will tell us even more about the physical properties of the proteins and provide more clues about potential therapies.”

The research was supported by the National Institutes of Health, the National Science Foundation, the Alliance for NanoHealth, the Welch Foundation, the Mary R. Gibson Foundation and the Everett Hinkson Fund. Study co-authors include Rice graduate students Sithara Wijeratne and Eric Frey, former Rice graduate student Eric Botello, BCM researchers Hui-Chun Yeh and Angela Bergeron, Rice undergraduate Jay Patel, PSBC’s Zhou Zhou and Rice senior research technicians Leticia Nolasco and Nancy Turner.

Source: *Science Daily Online*

Inspired by Deep Sea Sponges: Creating Flexible Minerals

Scientists at Johannes Gutenberg University Mainz (JGU) and the Max Planck Institute for Polymer Research (MPI-P) in Germany have created a new synthetic hybrid material with a mineral content of almost 90 per cent, yet extremely flexible. They imitated the structural elements found in most sea sponges and recreated the sponge spicules using the natural mineral calcium carbonate and a protein of the sponge. Natural minerals are usually very hard and prickly, as fragile as porcelain.

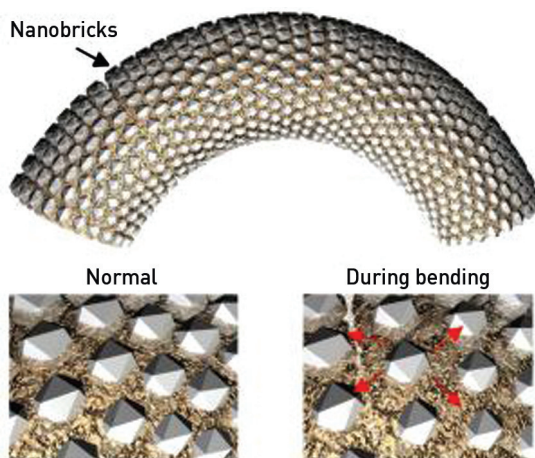

The nanometer size of the calcite bricks facilitates bending of the synthetic spicules. The radius of curvature upon bending is very large compared to the size of the individual particles. This prevents a fracture of the brittle mineral bricks. (Credit: Tremel work group, JGU)

Amazingly, the synthetic spicules are superior to their natural counterparts in terms of flexibility, exhibiting a rubber-like flexibility. The synthetic spicules can, for example, easily be U-shaped without breaking or showing any signs of fracture. This highly unusual characteristic, described by the German researchers in the current issue of *Science*, is mainly due to the part of organic substances in the new hybrid material. It is about ten times as much as in natural spicules.

Spicules are structural elements found in most sea sponges. They provide structural support and deter predators. They are very hard, prickly, and even quite difficult to cut with a knife. The spicules of sponges thus offer a perfect example of a lightweight, tough, and impenetrable defense system, which may inspire engineers to create body armours of the future.

The researchers led by Wolfgang Tremel, Professor at Johannes Gutenberg University Mainz, and Hans-Jürgen Butt, Director at the Max Planck Institute for Polymer Research in Mainz, used these natural sponge spicules as a model to cultivate them in the lab. The synthetic spicules were made from calcite (CaCO_3) and silicatein- α . The latter is a protein from siliceous sponges that, in nature, catalyses the formation of silica, which forms the natural silica spicules of sponges. Silicatein- α was used in the lab setting to control the self-organisation of the calcite spicules. The synthetic material was self-assembled from an amorphous calcium carbonate intermediate and silicatein and subsequently aged to the final crystalline material. After six months, the synthetic spicules consisted of calcite nanocrystals aligned in a brick wall fashion with the protein embedded like cement in the boundaries between the calcite nanocrystals. The spicules were of 10 to 300 micrometres in length with a diameter of 5 to 10 micrometres.

As the scientists, among them chemists, polymer researchers, and the molecular biologist Professor Werner E. G. Müller from the Mainz University Medical Center, also write in their *Science* publication, the synthetic spicules have yet another special characteristic, i.e., they are able to transmit light waves even when they are bent.

Source: *Science Daily Online*

Statistical Physics Offers a New Way to Look at Climate

Statistical physics offers an approach to studying climate change that could dramatically reduce the time and brute-force computing that current

simulation techniques require. The new approach focuses on fundamental forces that drive climate rather than on “following every little swirl” of water or air.

Scientists are using ever more complex models running on ever more powerful computers to simulate Earth’s climate. But new research suggests that basic physics could offer a simpler and more meaningful way to model key elements of climate.

The research, published in the journal *Physical Review Letters*, shows that a technique called direct statistical simulation does a good job of modeling fluid jets, fast-moving flows that form naturally in oceans and in the atmosphere. Brad Marston, Professor of physics at Brown University and one of the authors of the paper, says the findings are a key step toward bringing powerful statistical models rooted in basic physics to bear on climate science.

The method of simulation used in climate science now is useful but cumbersome, Marston said. The method, known as direct numerical simulation, amounts to taking a modified weather model and running it through long periods of time. Moment-to-moment weather — rainfall, temperatures, wind speeds at a given moment, and other variables — is averaged over time to arrive at the climate statistics of interest. Because the simulations need to account for every weather event along the way, they are mind-bogglingly complex, take a long time run, and require the world’s most powerful computers.

One practical advantage of the new approach: the ability to model climate conditions from millions of years ago without having to reconstruct the world’s entire weather history. Direct statistical

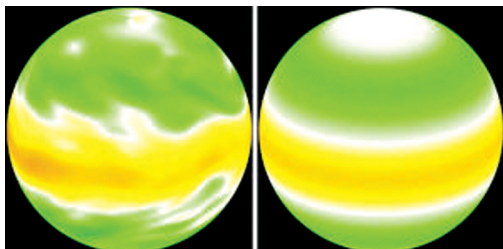

Two views, two approaches to simulation. Computer-generated images of a planet's "zonal velocity" (the west-to-east component of wind) use direct numerical simulation (the traditional approach, left) and direct statistical simulation. The latter has limits, but its development is at a very early stage. (Credit: Marston lab/Brown University)

simulation, on the other hand, is a new way of looking at climate. "The approach we're investigating," Marston said, "is the idea that one can directly find the statistics without having to do these lengthy time integrations."

It's a bit like the approach physicists use to describe the behavior of gases.

"Say you wanted to describe the air in a room," Marston said. "One way to do it would be to run a giant supercomputer simulation of all the positions of all of the molecules bouncing off of each other. But another way would be to develop statistical mechanics and find that the gas actually obeys simple laws you can write down on a piece of paper: $PV=nRT$, the gas equation. That's a much more useful description, and that's the approach we're trying to take with the climate."

Conceptually, the technique focuses attention on fundamental forces driving climate, instead of "following every little swirl," Marston said. A practical advantage would be the ability to model climate conditions from millions of years ago

without having to reconstruct the world's entire weather history in the process.

The theoretical basis for direct statistical simulation has been around for nearly 50 years. The problem, however, is that the mathematical and computational tools to apply the idea to climate systems aren't fully developed. That is what Marston and his collaborators have been working on for the last few years, and the results in this new paper show their techniques have good potential.

The paper, which Marston wrote with University of Leeds mathematician Steve Tobias, investigates whether direct statistical simulation is useful in describing the formation and characteristics of fluid jets, narrow bands of fast-moving fluid that move in one direction. Jets form naturally in all kinds of moving fluids, including atmospheres and oceans. On Earth, atmospheric jet streams are major drivers of storm tracks.

For their study, Marston and Tobias simulated the jets that form as a fluid moves on a hypothetical spinning sphere. They modeled the fluid using both the traditional numerical technique and their statistical technique, and then compared the output of the two models. They found that the models generally arrived at similar values for the number of jets that would form and the strength of the airflow, demonstrating that statistical simulation can indeed be used to model jets.

There were limits, however, to what the statistical model could do. The study found that as pace of adding and removing energy to the fluid system increased, the statistical model started to break down. Marston and Tobias are currently working on an expansion of their technique to deal with that problem.

Despite the limitation, Marston is upbeat about the potential for the technique. “We’re very pleased that it works as well as it did here,” he said.

Since completing the study, Marston has integrated the method into a computer program called “GCM” that he has made easily available via Apple’s Mac App Store for other researchers to download. The programme allows users to build their own simulations, comparing numerical and statistical models. Marston expects that researchers who are interested in this field will download it and play with the technique on their own, providing new insights along the way. “I’m hoping that citizen-scientists will also explore climate modeling with it as well, and perhaps make a discovery or two,” he said.

There’s much more work to be done on this, Marston stresses, both in solving the energy problem and in scaling the technique to model more realistic climate systems. At this point, the simulations have only been applied to hypothetical atmospheres with one or two layers. Earth’s atmosphere is a bit more complex than that.

“The research is at a very early stage,” Marston said, “but it’s picking up steam.”

Source: *Science Daily Online*

Playing Action Video games Improves Visual Search

Researchers at the University of Toronto have shown that playing shooting or driving video games, even for a relatively short time, improves

the ability to search for a target hidden among irrelevant distractions in complex scenes.

“Recent studies in different labs, including here at the University of Toronto, have shown that playing first-person shooter video games can enhance other aspects of visual attention,” says psychology professor Ian Spence. “But no one has previously demonstrated that visual search is also improved.”

Searching efficiently and accurately is essential for many tasks. “It’s necessary for baggage screening, reading X rays or MRIs, interpreting satellite images, defeating camouflage or even just locating a friend’s face in a crowd,” says Spence.

In the first experiment, the researchers compared action videogame players and non-players on three visual search tasks and found that the experienced players were better.

“But this difference could be a result of a pre-existing superiority in experienced gamers compared to those who avoid them, says Sijing Wu, a PhD candidate in Spence’s lab in U of T’s Department of Psychology and lead author of the study. “A training experiment was necessary to establish whether playing an action game could actually improve search skills.”

In the second experiment, 60 participants — who had not previously played videogames — played for a total of 10 hours in one to two hour sessions. Twenty participants were randomly assigned to play the first-person shooter game, Medal of Honor, 20 to a driving-racing game, Need for Speed and 20 to a three-dimensional puzzle game, Ballance as a control.



Researchers at the University of Toronto have shown that playing shooting or driving videogames, even for a relatively short time, improves the ability to search for a target hidden among irrelevant distractions in complex scenes. (Credit: © tomispin / Fotolia)

“After playing either the shooter or driving game for only 10 hours, participants were faster and more accurate on the three visual search tasks,” says Wu. “However, the control participants — who played the puzzle game — did not improve.”

“We have shown that playing a driving-racing game can produce the same benefits as a shooter game,” says Wu. “This could be very important in situations where we wish to train visual search skills. Driving games are likely to be more acceptable than shooting games because of the lower levels of violence.”

Source: Science Daily Online

New Vaccine-Design Approach Targets Viruses Such as HIV

A team led by scientists from The Scripps Research Institute (TSRI) and the International AIDS Vaccine Initiative (IAVI) has unveiled a new technique for vaccine design that could be particularly useful against HIV and other fast-changing viruses.

The report, which appears 28 March 2013, in *Science Express*, the early online edition of the journal *Science*, offers a step toward solving what has been one of the central problems of modern vaccine design: how to stimulate the immune system to produce the right kind of antibody response to protect against a wide range of viral strains. The researchers demonstrated their new technique by engineering an immunogen (substance that induces immunity) that has promise to reliably initiate an otherwise rare response effective against many types of HIV.

“We’re hoping to test this immunogen soon in mice engineered to produce human antibodies, and eventually in humans,” said team leader William R. Schief, who is an Associate Professor of immunology and member of the IAVI Neutralising Antibody Center at TSRI.

Seeking a Better Way

For highly variable viruses such as HIV and influenza, vaccine researchers want to elicit antibodies that protect against most or all viral strains — not just a few strains, as seasonal flu vaccines currently on the market. Vaccine researchers have identified several of these broadly neutralising antibodies from long-term HIV-positive survivors, harvesting antibody-producing B cells from blood samples and then sifting through them to identify those that produce antibodies capable of neutralising multiple strains of HIV. Such broadly neutralising antibodies typically work by blocking crucial functional sites on a virus that are conserved among different strains despite high mutation elsewhere.

However, even with these powerful broadly neutralising antibodies in hand, scientists need to find a way to elicit their production in the body through a vaccine. “For example, to elicit broadly neutralising antibodies called VRC01-class antibodies that neutralize 90 per cent of known HIV strains, you could try using the HIV envelope protein as your immunogen,” said Schief, “but you run into the problem that the envelope protein doesn’t bind with any detectable affinity to the B cells needed to launch a broadly neutralising antibody response.”

To reliably initiate that VRC01-class antibody response, Schief and his colleagues therefore sought to develop a new method for designing vaccine immunogens.

From Weak to Strong

Joseph Jardine, a TSRI graduate student in the Schief laboratory, evaluated the genes of VRC01-producing B cells in order to deduce the identities of the less mature B cells — known as germline B cells — from which they originate. Germline B cells are major targets of modern viral vaccines, because it is the initial stimulation of these B cells and their antibodies that leads to a long-term antibody response.

In response to vaccination, germline B cells could, in principle, mature into the desired VRC01-producing B cells — but natural HIV proteins fail to bind or stimulate these germline B cells so they cannot get the process started. The team thus set out to design an artificial immunogen that would be successful at achieving this.



The researchers demonstrated their new technique by engineering a compound that has promise to initiate an otherwise rare immune response against many types of HIV. Here, the germline-targeting immunogen eOD-GT6 (red) is shown bound to its target, the germline VRC01 antibody (magenta and yellow). (Credit: Photo courtesy of The Scripps Research Institute.)

Jardine used a protein modeling software suite called Rosetta to improve the binding of VRC01 germline B cell antibodies to HIV’s envelope protein. “We asked Rosetta to look for mutations on the side of the HIV envelope protein that would help it bind tightly to our germline antibodies,” he said.

Rosetta identified dozens of mutations that could help improve binding to germline antibodies. Jardine then generated libraries that contained all possible combinations of beneficial mutations, resulting in millions of mutants, and screened them using techniques called yeast surface display and FACS. This combination of computational

prediction and directed evolution successfully produced a few mutant envelope proteins with high affinity for germline VRC01-class antibodies.

Jardine then focused on making a minimal immunogen — much smaller than HIV envelope — and so continued development using the “engineered outer domain (eOD)” previously developed by Po-Ssu Huang in the Schief lab while Schief was at the University of Washington. Several iterative rounds of design and selection using a panel of germline antibodies produced a final, optimised immunogen — a construct they called eOD-GT6.

A Closer Look

To get a better look at eOD-GT6 and its interaction with germline antibodies, the team turned to the laboratory of Ian A. Wilson, chair of the Department of Integrative Structural and Computational Biology and a member of the IAVI Neutralising Antibody Center at TSRI.

Jean-Philippe Julien, a senior research associate in the Wilson laboratory, determined the 3D atomic structure of the designed immunogen using X-ray crystallography — and, in an unusual feat, also determined the crystal structure of a germline VRC01 antibody, plus the structure of the immunogen and antibody bound together.

“We wanted to know whether eOD-GT6 looked the way we anticipated and whether it bound to the antibody in the way that we predicted — and in both cases the answer was ‘yes’,” said Julien. “We also were able to identify the key mutations that conferred its reactivity with germline VRC01 antibodies.”

Mimicking a Virus

Vaccine researchers know that such an immunogen typically does better at stimulating an antibody response when it is presented not as a single copy but in a closely spaced cluster of multiple copies, and with only its antibody-binding end exposed. “We wanted it to look like a virus,” said Sergey Menis, a visiting graduate student in the Schief laboratory.

Menis therefore devised a tiny virus-mimicking particle made from 60 copies of an obscure bacterial enzyme and coated it with 60 copies of eOD-GT6. The particle worked well at activating VRC01 germline B cells and even mature B cells in the lab dish, whereas single-copy eOD-GT6 did not.

“Essentially it’s a self-assembling nanoparticle that presents the immunogen in a properly oriented way,” Menis said. “We’re hoping that this approach can be used not just for an HIV vaccine but for many other vaccines, too.”

The next step for the eOD-GT6 immunogen project, said Schief, is to test its ability to stimulate an antibody response in lab animals that are themselves engineered to produce human germline antibodies. The difficulty with testing immunogens that target human germline antibodies is that animals typically used for vaccine testing cannot make those same antibodies. So the team is collaborating with other researchers who are engineering mice to produce human germline antibodies. After that, he hopes to learn how to drive the response, from the activation of the germline B cells all the way to the production of mature, broadly neutralising VRC01-class antibodies, using a series of designed immunogens.

Schief also hopes they will be able to test their germline-targeting approach in humans sooner rather than later, noting “it will be really important to find out if this works in a human being.”

The first authors of the paper, “Rational HIV immunogen design to target specific germline B cell receptors,” were Jardine, Julien and Menis. Co-authors were Takayuki Ota and Devin Sok of the Nemazee and Burton laboratories at TSRI, respectively; Travis Nieuwma of the Ward laboratory at TSRI; John Mathison of the Ulevitch laboratory at TSRI; Oleksandr Kalyuzhniy and Skye MacPherson, researchers in the Schief laboratory from IAVI and TSRI, respectively; Po-Ssu Huang and David Baker of the University of Washington, Seattle; Andrew McGuire and Leonidas

Stamatatos of the Seattle Biomedical Research Institute; and TSRI principal investigators Andrew B. Ward, David Nemazee, Ian A. Wilson, and Dennis R. Burton, who is also head of the IAVI Neutralizing Center at TSRI.

The project was funded in part by IAVI; the National Institutes of Health (AI84817, AI081625 and AI33292); and the Ragon Institute.

Source: Science Daily Online

Compiled and Edited by

PROFESSOR SUNITA FARKYA
DESM, NCERT, New Delhi

MERINA HENAM
Junior Project Fellow, DESM, NCERT, New Delhi

WEB WATCH

In this Section, we present websites and a brief introduction about them. Inclusion of a site does not imply that School Science endorses the content of the site. Sites have been suggested on the basis of their possible utility to school systems.



- **Cmap Tools**
<http://cmap.ihmc.us>

These tools were developed at the Institute of Human and Machine Cognition (IHMC), Florida University, USA. It is a software toolkit which can be downloaded free. It empowers users to construct, navigate, share and criticise knowledge models represented as concept maps. CmapTools is used worldwide in all domains of knowledge.

- **Imagine the Universe**
<http://imagine.gsfc.nasa.gov>

This website from NASA is intended for students of age 14 and up, and for anyone interested in learning about universe. It has links, namely; Science, Special Exhibits, Satellite and data, Teacher corners, Dictionary and resources. The website also provides the, 'Ask an Astrophysicist' service though which users can ask a question. It also provides pathways to astronomy education resources.

- **Microbe Passports**
www.microbiologyonline.org.uk/students/microbe-passport

Microbes are microscopic organisms and we can not see them. They are of different sizes and exist inside the bodies of animal and plants. They are found in soils and rocks also. Microbes include photosynthetic bacterias, HIV viruses, bifida, measles and TB. The site also provides a virtual microscope to see the images of different types of microbes.



- **www.redorbit.com**

This website was launched in May 2003 with the goal of promoting news related to science, health, space and technology. The organisation RedOrbit, Inc, was founded by Eric Ralls in November 2002, its headquarter is located in Texas. The website is engaged in promoting stimulating and authentic presentations pertaining to science, health, space and technology. It is an intellectual platform for enhancing knowledge.

Compiled and Edited by

PROFESSOR SUNITA FARKYA
DESM, NCERT, New Delhi

MERINA HENAM
Junior Project Fellow, DESM, NCERT, New Delhi

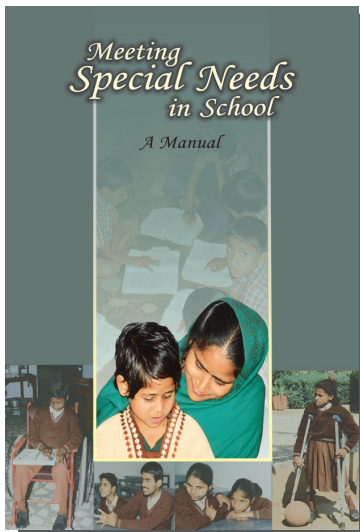

Meeting Special Needs in Schools

A Manual

₹ 45.00/pp 66

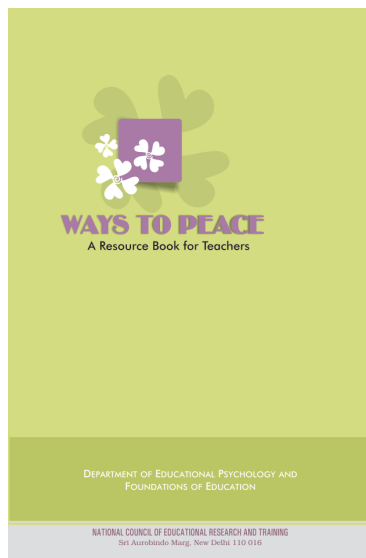

Ways to Peace

A Resource Book for Teachers

₹ 110.00/pp 186

For further enquiries, please visit www.ncert.nic.in or contact the Business Managers at the addresses of the regional centres given on the copyright page

Some other NCERT Publications

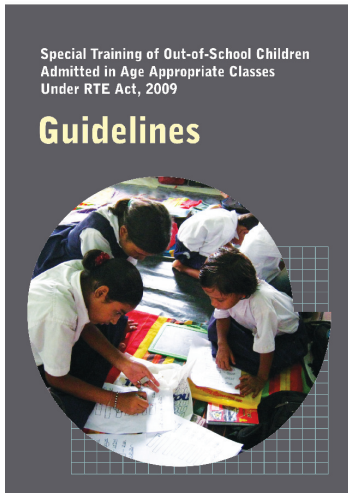

₹ 47.00/pp 54

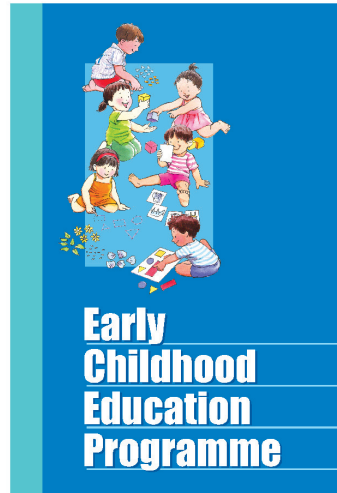

₹ 195.00/pp 300

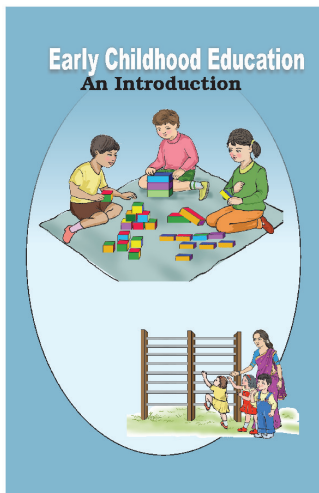

₹ 25.00/pp 38

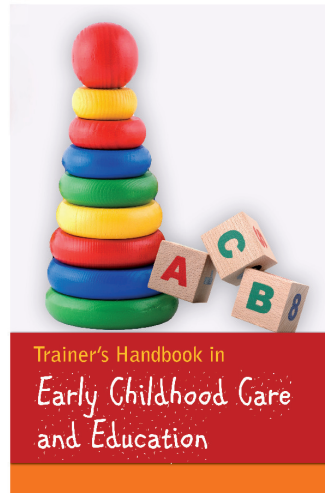

₹ 110.00/pp 224

For further enquiries, please visit www.ncert.nic.in or contact the Business Managers at the addresses of the regional centres given on the copyright page

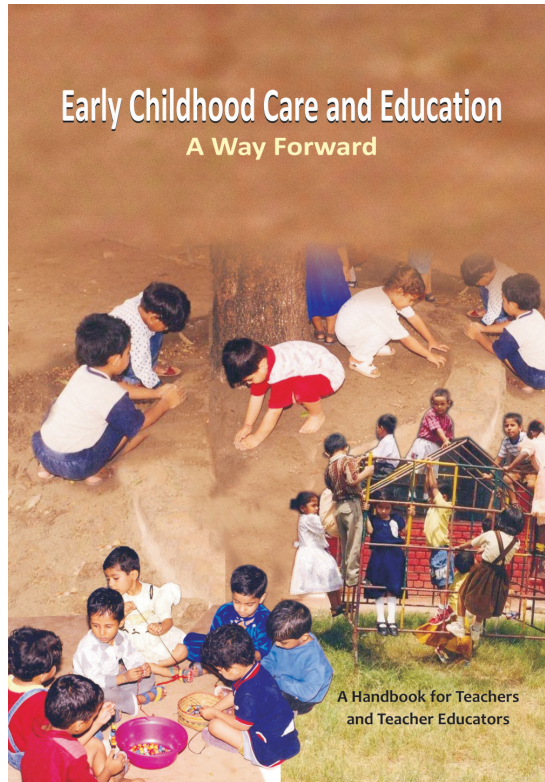

Early Childhood Care and Education : A Way Forward
₹ 140.00 /Pages 268

For further enquiries, please visit www.ncert.nic.in or contact the Business Managers at the addresses of the regional centres given on the copyright page

Form IV (See Rule 8) SCHOOL SCIENCE

- | | |
|---|---|
| 1. Place of Publication | National Council of Educational Research and Training (NCERT) |
| 2. Periodicity of Publication | Quarterly |
| 3. Printer's Name
(Whether citizen of India?)
(If foreigner, state the country of origin)
Address | Manoj Sharma
Yes
Not applicable
Proprietor : Chaar Dishayen Printers Pvt.
Ltd. G-40 Sector-3 Noida (U.P.) 201 301 |
| 4. Publisher's Name
(Whether citizen of India?)
(If foreigner, state the country of origin)
Address | Ashok Srivastava
Yes
Not applicable
Head, Publication Division, NCERT
Sri Aurobindo Marg, New Delhi 110 016 |
| 5. Editor's Name
(Whether citizen of India?)
(If foreigner, state the country of origin)
Address | Sunita Farkya
Yes
Not applicable
Academic Editor (JIE), DESM, NCERT
New Delhi 110 016 |
| 6. Names and addresses of the individuals who own the newspaper and partner or shareholders holding more than one per cent of the total capital | National Council of Educational Research and Training, New Delhi
(An autonomous body of the Government of India in the Ministry of Human Resource Development) |

I, Ashok Srivastava, hereby declare that the particulars given above are true to the best of my knowledge and belief.

Publisher

Published at the Publication Division by the Secretary, National Council of Educational Research and Training, Sri Aurobindo Marg, New Delhi 110 016 and printed at Chaar Dishayen Printers Pvt. Ltd. G-40 Sector-3 Noida (U.P.) 201 301

Subscription Rates for NCERT Journals

Title	Single Copy	Annual Subscription
School Science A Quarterly Journal of Science Education	₹55.00	220.00
Indian Educational Review A Half-yearly Research Journal	₹50.00	100.00
Journal of Indian Education A Quarterly Journal of Education	₹45.00	180.00
भारतीय आधुनिक शिक्षा (त्रैमासिक) (Bhartiya Aadhunik Shiksha) A Quarterly Journal in Hindi	₹50.00	200.00
Primary Teacher A Quarterly Journal for Primary Teachers	₹65.00	260.00
प्राथमिक शिक्षक (त्रैमासिक) (Prathmik Shikshak) A Quarterly Journal in Hindi for Primary Teachers	₹65.00	260.00

Subscriptions are invited from educationists, institutions, research scholars, teachers and students for the journals published by the NCERT

For further enquiries, please write to:

Chief Business Manager, Publication Division

National Council of Educational Research and Training

Sri Aurobindo Marg, New Delhi 110 016

E-mail : gg_cbm@rediffmail.com, Phone : 011-26562708 Fax : 011-26851070

विद्यया ऽ मृतमश्नुते



एन सी ई आर टी
NCERT

राष्ट्रीय शैक्षिक अनुसंधान और प्रशिक्षण परिषद्
NATIONAL COUNCIL OF EDUCATIONAL RESEARCH AND TRAINING